



### Vented loops:

If the toilet is connected to any through-hull fitting and if the rim of the bowl falls below the waterline, for example during heavy seas, there is the risk of water flooding in, causing the boat to sink, which may result in loss of life. Therefore, if the rim of the toilet is less than 20 cm (8") above the waterline when the craft is at rest, or if there is any possibility that the rim of the bowl may be below the waterline at **ANY** time, a **vented loop MUST** be fitted in any pipework connected to a through-hull fitting, irrespective of whether inlet or discharge. **The loop must be vented to avoid the siphoning of water back into the boat through the toilet.** If the toilet is connected to any through-hull fitting and if the rim of the bowl falls below the waterline, for example during heavy seas, there is the risk of water flooding in, causing the boat to sink, which may result in loss of life. Therefore, if the rim of the toilet is less than 20 cm (8") above the waterline when the craft is at rest, or if there is any possibility that the rim of the bowl may be below the waterline at **ANY** time, a **vented loop MUST** be fitted in any pipework connected to a through-hull fitting, irrespective of whether inlet or discharge. **The loop must be vented to avoid the siphoning of water back into the boat through the toilet.**

### Vented Loop fittings

**Toilet below waterline or below holding tank** Inlet: 19 mm (3/4") Vented Loop fitting

- The vented loop must be positioned in a way that its highest point is 20 – 50 cm (8 – 20") above the highest possible waterline
- Run the inlet hose by the most direct way from the inlet seacock, via the flush pump to the vented loop; or, the most direct way from the pressurized water pipe in a centralized system.
- Run the inlet hose by the most direct way from the vented loop to toilet flushing pump inlet connection.
- Discharge: 25 mm (1") or 38 mm (1 1/2") Vented Loop fitting Mounting
- Arrange the discharge hose, so that its highest point is at least 20 cm (8") above the waterline or holding tank, and fit the vented loop at the highest point.
- Run the discharge hose from the toilet to the vented loop
- Run the discharge hose from the vented loop to the seacock or holding

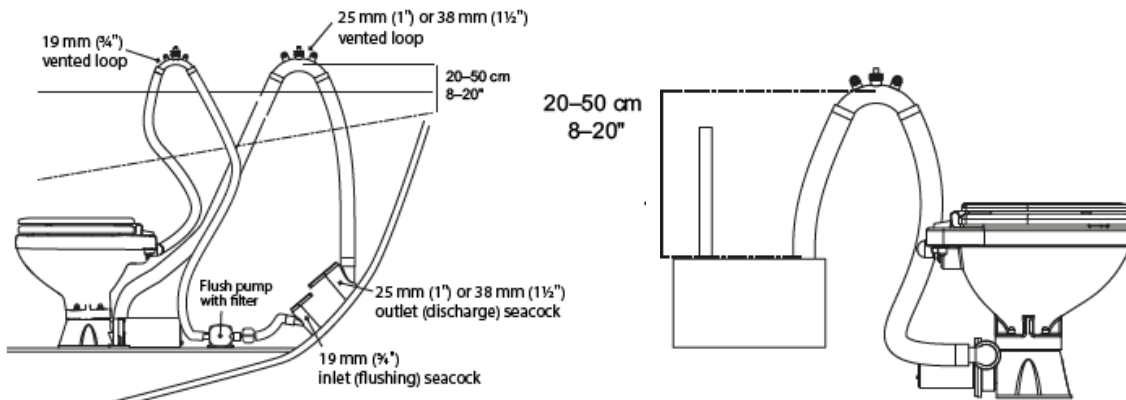

**Toilet above waterline or above holding tank** Inlet: 19 mm hose

- Run the inlet hose by the most direct route from the inlet seacock to a non-return valve; or, the most direct way from the pressurized water pipe in a centralized system.
- Run the inlet hose from the non-return valve to the flush pump and then to the flushing pump inlet connection.
- For convenience of use, install an in-line non-return valve next to the inlet seacock which will ensure that the pump stays primed in between usages.
- Discharge: 25 mm (1") or 38 mm (1 1/2") hose
- Arrange the discharge hose, so that its highest point is 20 – 50 cm (8 – 20") above the waterline or holding tank, and fit the vented loop at the highest point.
- Run the discharge hose from the toilet to the vented loop
- Run the discharge hose from the vented loop to the seacock or holding tank
- By fitting a Vented Loop on top of the hose loop, you will ensure to keep some water in the base of the toilet with out risk of it being siphoned away.

