

Crewsaver®



USER MANUAL



CREWFIT 165 SPORT

REGULATION (EU) 2016/425

Owners Manual

IMPORTANT: PLEASE READ THIS MANUAL
BEFORE USING YOUR CREWFIT LIFEJACKET



BS EN ISO 12402-3:2006+A1:2010

THE CREWFIT 165N SPORT LIFEJACKET

150N LIFEJACKETS

This level 150N lifejacket will give a reasonable assurance of safety from drowning to a person who, for whatever reason, is no longer capable of helping themselves fully. This level is intended for general application or for use with foul weather clothing. It will turn an unconscious person into a safe position and requires no subsequent action by the user to maintain this position. This jacket is suitable for offshore use.



IMPORTANT INFORMATION

- Train yourself in the use of this device
- Do not use as a cushion

CREWFIT 165^{SPORT}

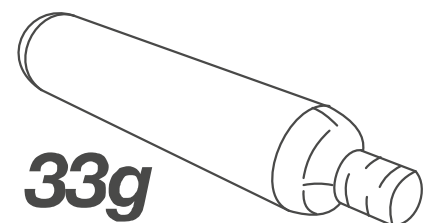
- ISO12402-3 approved
- High performance 165N Inflation chamber
- Exceptional turning speeds
- Hard wearing outer cover
- Single soft loop deck safety harness on harness version
- ISO 12401:2009
- Twin burst cover zip
- Rapid adjusting buckle for perfect fit
- Single lifting becket
- Single crotch strap*
- Whistle
- Optional SOLAS approved light

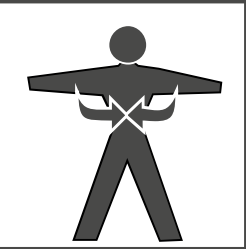
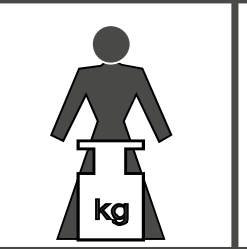
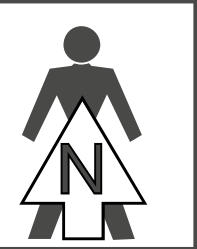

				
LEVEL 150 PFD	ADULT	75-155cm	> 40 kg	150N

*Purchased as an optional extra on lifejackets sold into Australia

DONNING YOUR LIFEJACKET

DONNING THE CREWFIT 165N SPORT LIFEJACKET

- 1 & 2 Don like a normal jacket.
- 3 Fasten front buckle.
- 4 Adjust waist belt by pulling side webbing backwards for a close secure fit.
- 5 Fasten crotch strap* buckle and adjust straps by pulling webbing downwards for a close secure fit.

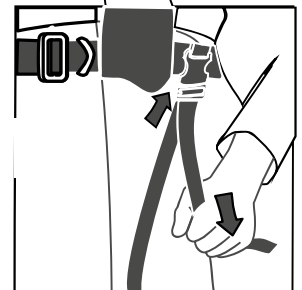
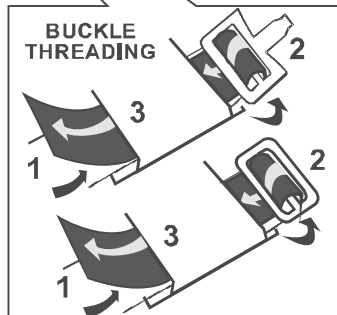
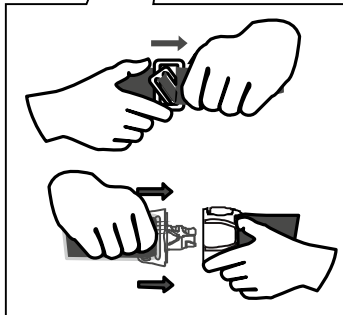

*Purchased as an optional extra on lifejackets sold into Australia

KNOW YOUR INFLATION TYPE

KNOW YOUR INFLATION MECHANISM TYPE

1. Check that the firing lever (A) is closed and the green security saddle (B) is clipped over the lever securely.
2. Ensure that the inflation toggle (C) is present and accessible.
3. Check that the CO₂ cylinder (D) is securely screwed into the operating mechanism (E) and fitted with EXOLOK mechanism and label (F) and mesh sleeve (G) has been fitted.
4. Check that the nut/screw (H), securing the inflation mechanism to the inflation chamber is not loose.

For Automatic inflation only, Check that the automatic firing capsule (I) is screwed fully onto the operating mechanism (E). Ensure that the capsule (I) has not been fired inadvertently by checking that the bottom indicator shows green (J). Also check the expiry date on the side of the capsule. Do not use a capsule that is out of date.

MANUAL OPERATING MECHANISM (HALKEY ROBERTS):

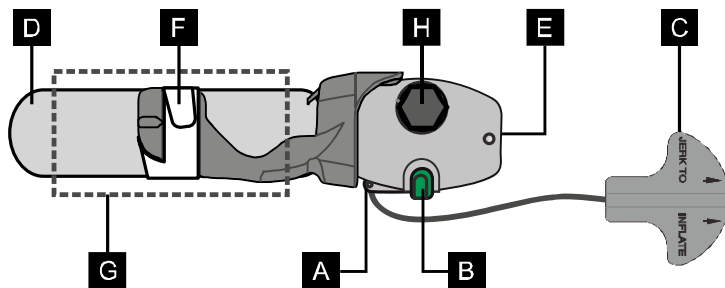

AUTOMATIC MECHANISM (UML MK5 AUTO):

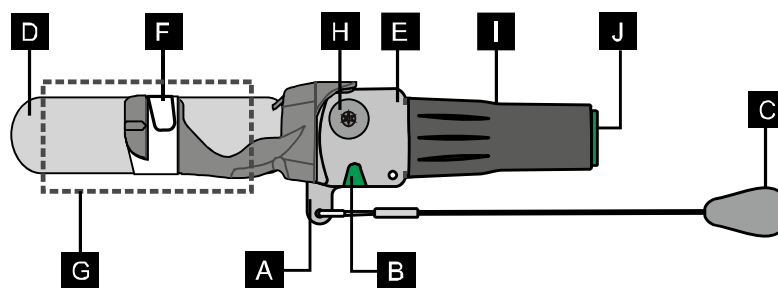

WELDED MINI-MANUAL MECHANISM (HALKEY ROBERTS):

- 1 Check that the green manual firing indicator is present (D); that the pull to inflate lanyard (C) is present.
- 2 Check the correct size 33g CO₂ cylinder (A) is securely screwed into the inflator body (B) by feeling through the fabric.

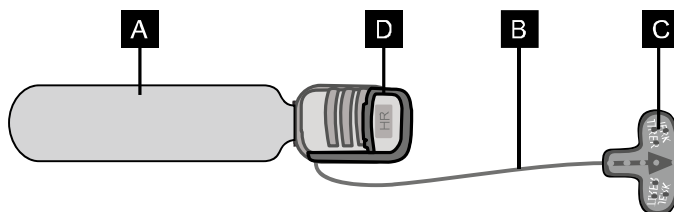

RE-ARMING

RE-ARMING YOUR AUTOMATIC OPERATING MECHANISM

1. If fired manually replace the firing arm into the main body and fit the retaining clip. The clip is fitted by pressing it over the firing arm and into the recess either side in the center of the operating mechanism.
2. Take the new Automatic firing capsule and screw onto the operating mechanism in a clockwise direction. Screw right up ensuring there is no gap between the capsule and the base of the operating mechanism. Do up hand tight.
3. Check that the cylinder-sealing gasket in the end of the operating mechanism has been correctly fitted, or replaced if necessary. Check the new CO₂ cylinder has not been used. Fit EXOLOK mechanism (A) and screw cylinder into the main body in a clockwise direction (B). Ensure the cylinder is screwed right down and hand tighten. The top indicator will turn green when the cylinder is tightened correctly. Secure with EXOLOK label (C) then fit mesh sleeve.

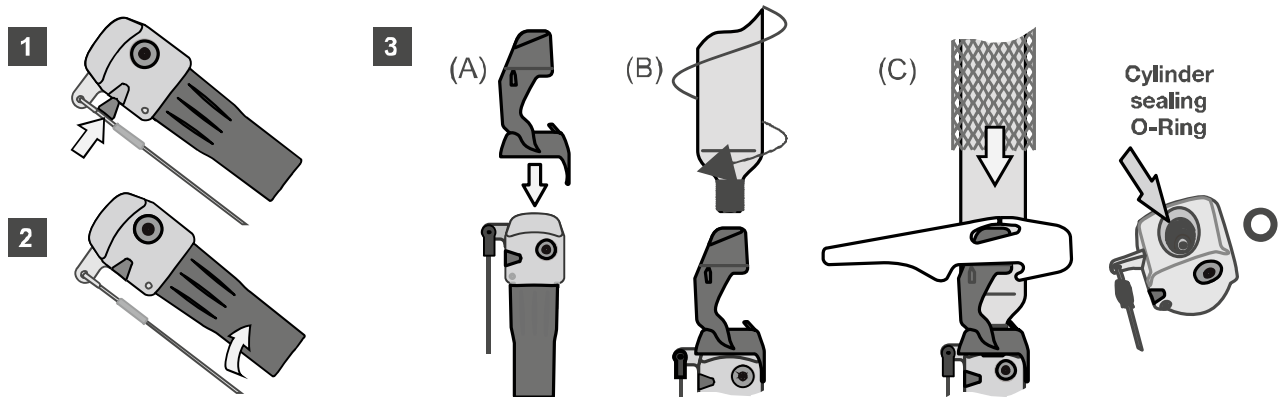

RE-ARMING YOUR MANUAL OPERATING MECHANISM

Always re-arm your lifejacket ready for use before you stow it away.

1. Unscrew the 33gm cylinder from manual firing head.
2. Check that the cylinder-sealing gasket in the end of the operating mechanism has been correctly fitted, or replaced if necessary. Check the new CO₂ cylinder has not been used. Reposition firing lever and secure with security saddle.
3. Screw the replacement 33gm cylinder and ensure it is hand tighten.
HR 840 ONLY!! Fit EXOLOK mechanism (A) and screw cylinder into the main body in a clockwise direction (B). Ensure the cylinder is screwed right down and hand tighten. Secure with EXOLOK label (C) then fit mesh sleeve.

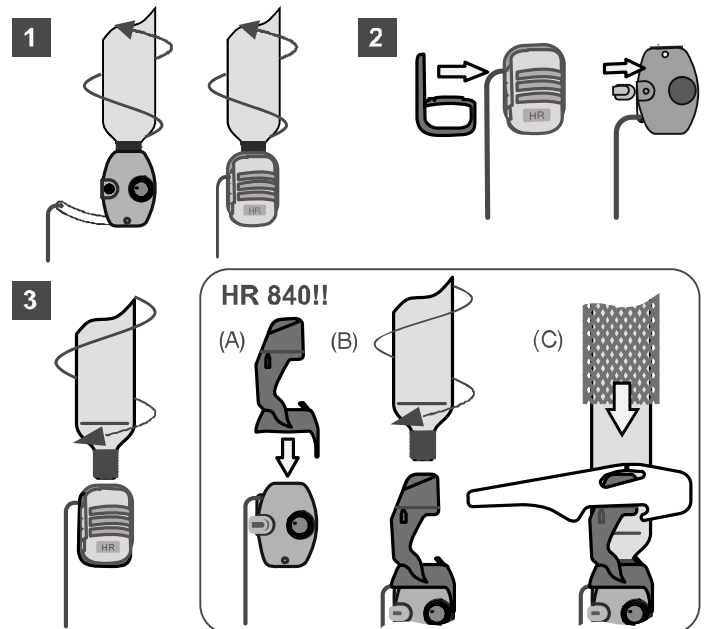

WARNING: If you are unsure or have any doubt how to re-arm and repack your lifejacket return the product to Crewsaver or your nearest Crewsaver service agent.



SPRAY HOOD & LIFTING BECKET

ATTACHING A CREWSAVER SPRAY HOOD TO YOUR CREWFIT (SOLD SEPARATELY)

- 1 Undo the popper on the back of the spray hood carry pouch.
- 2 Place the spray hood carry pouch on the waist belt with the popper facing inwards.
- 3 Fasten the popper to secure the spray hood to the waist belt.

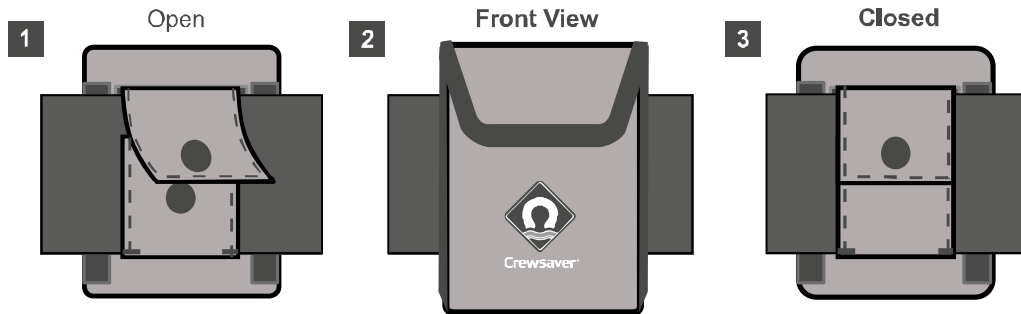

USING SPRAY HOODS WITH YOUR CREWFIT LIFEJACKET

Familiarise yourself with how the spray hood works if needed in an emergency.

- 1 Unpack your hood from it's carry pouch, unwinding the safety cord.
- 2 Pass the toggle through the spray hood loop on the bladder retainer webbing. Pull the hood over your head.
- 3 Locate the elastic securing strap and pull them over the inflated bladder chamber.
- 4 Your hood is now securely fitted to your Crewfit

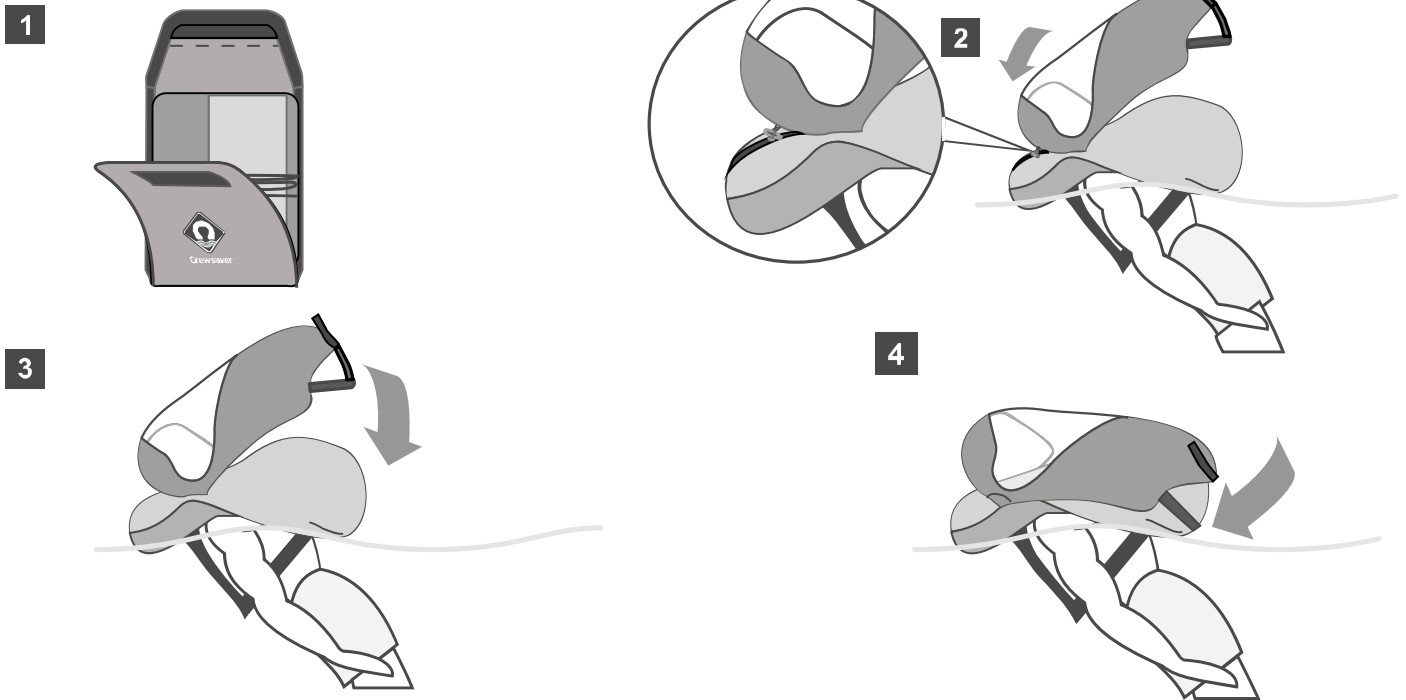

CORRECT USE OF LIFTING BECKET

- 1 Lifting becket is located below the left lobe of the inflation chamber.
- 2 Use lifting becket to haul casualties from the water.

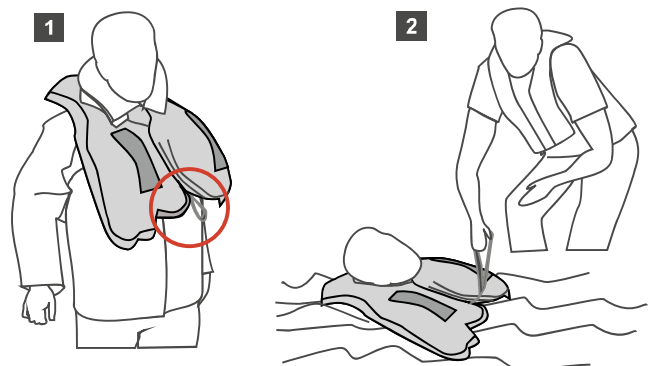

UNPACKING YOUR LIFEJACKET

OPENING THE LIFEJACKET COVER



1. Open the velcro tab.
2. To avoid damaging your lifejacket zip, pull apart the zip, open the zip via the quick burst elements, holding the cover either side.
3. Once the zip has opened, insert your finger and slide it around the lifejacket. Undo the zip all the way around the outside of the lifejacket. The lifejacket cover should now be open and the inflation chamber visible. Fully separate the zip. Both sides of the zip should be apart, with the zip slider free to move back around the lifejacket to the start.

PREPARING ZIP FOR RE-PACKING

1. Ensure that the zip slider is separated on one side.
2. Slide the zip around to the right side of the jacket as worn.
3. Feed the zip teeth into the slider ready to re-pack.

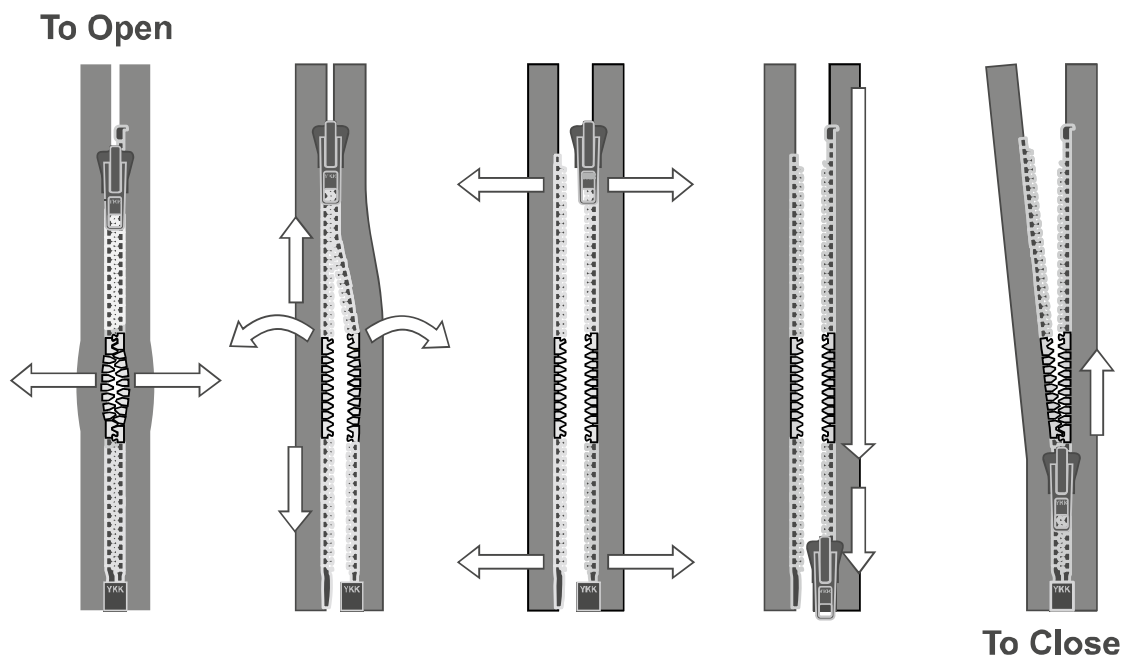

REPACKING YOUR LIFEJACKET

Ensure that your lifejacket is completely dry before packing.

(Refer to 'Care and Maintenance' for details on storing and cleaning your lifejacket)

- 1 Run the zip slider round to the left side of the jacket. *(Refer to 'Opening the lifejacket cover')*
- 2 Fold the bottom left of chamber up over operating head.
- 3 Fold in half to make a concertina underneath the Inflation mechanism. Start to close the zip.
- 4 Fold inner side over to the other side.
- 5 Fold the outside edge over the firing mechanism.
- 6 Tuck chamber inside the cover and secure in place with the velcro tabs.
- 7 Do up zip past Velcro tab. Ensure the manual pull toggle is accessible.
- 8 Fold the right side chin support diagonally underneath itself.
- 9 Fold the bottom right of the chamber up over the oral tube.
- 10 Fold inner edge over to the right ensuring lifting becket is folded up into the cover.
- 11 Fold the outside edge over.
- 12 Tuck chamber inside the cover.
- 13 Secure cover in place with the velcro tabs.
- 14 Concertina the chamber collar with two folds and tuck in the neck retainer.
- 15 Fold in the last corners of the chamber and bring the zip round to close.
- 16 Make sure Velcro tabs are secure and zip ends are tucked up inside the cover.

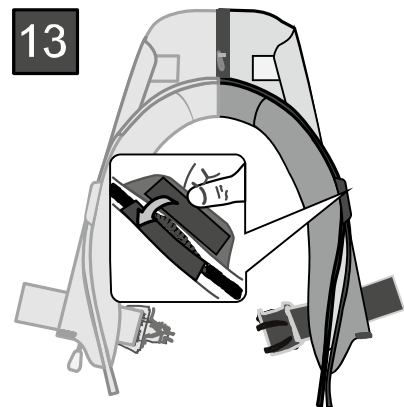
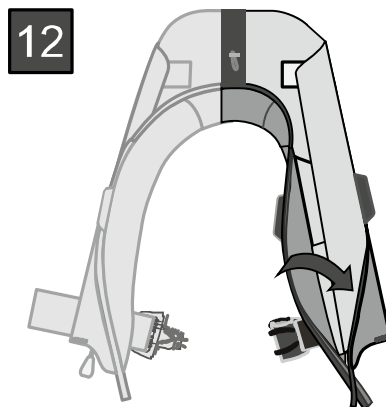
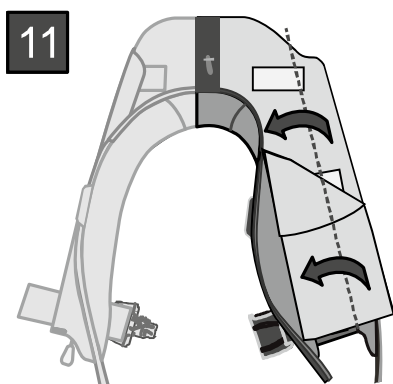
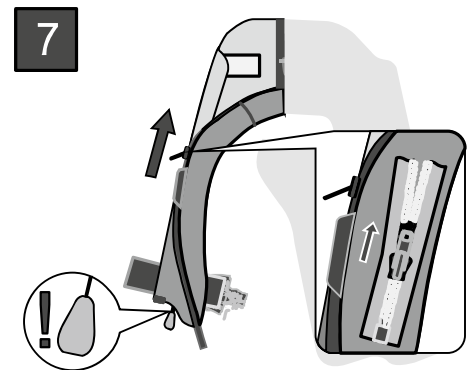
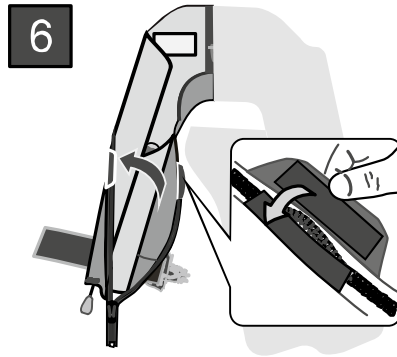
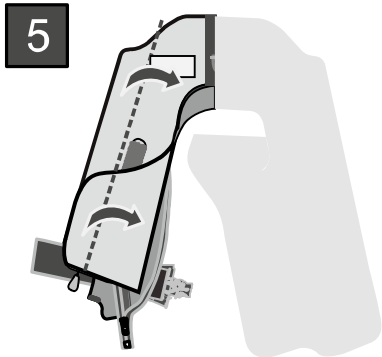

REPACKING YOUR LIFEJACKET

1

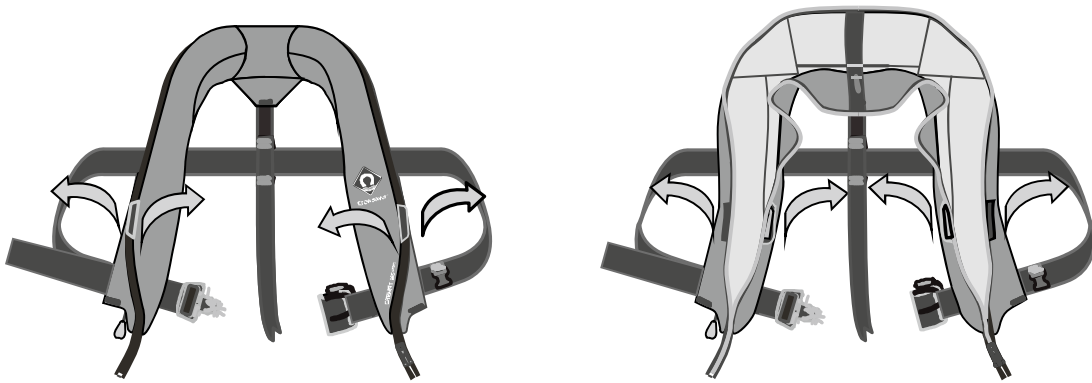

2

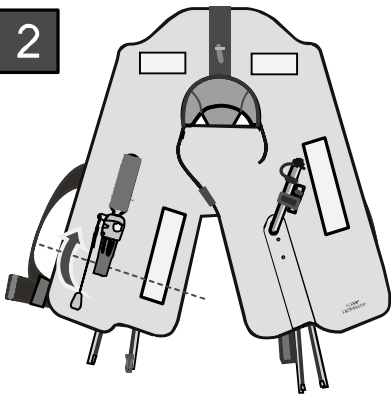

3

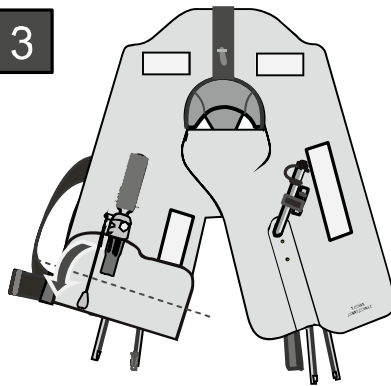

4

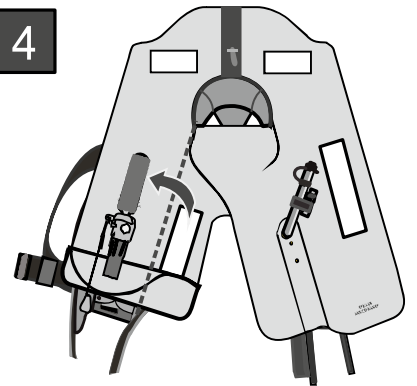

8

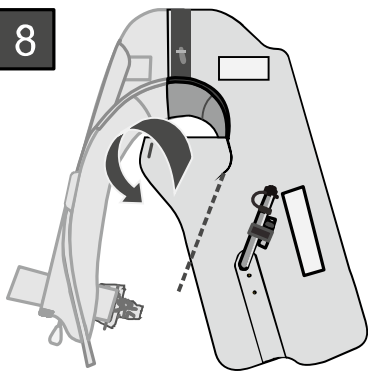

9

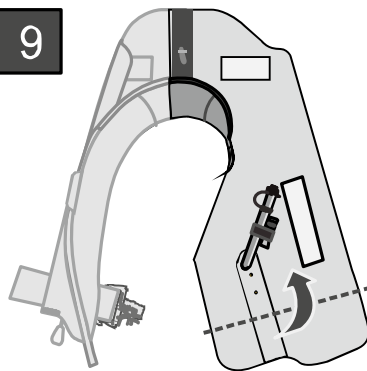

10

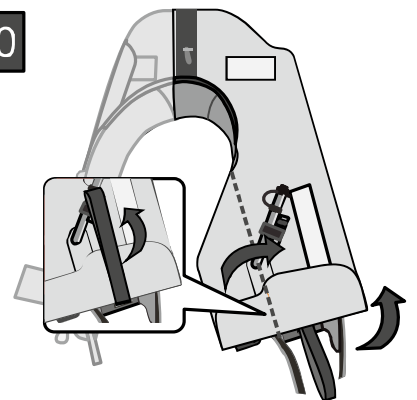

14

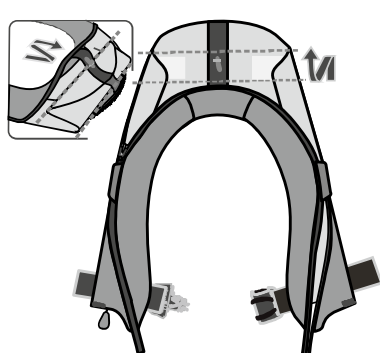

15

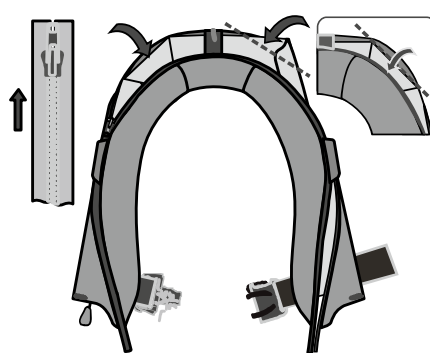

16

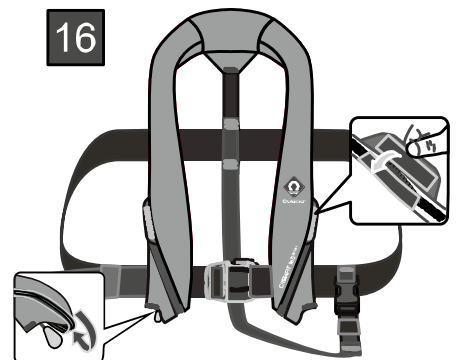

CARE & MAINTENANCE

Your lifejacket is an important item of technical safety equipment. The working life of the lifejacket will be prolonged if the following instructions are adhered to:

- Check that both status indicators are displaying green
- Check the expiry date, if any items have expired they **MUST** be replaced before use
- (Refer to 'Re-arming your lifejacket') for details on how to fit a new capsule
- Ensure a fully charged cylinder is tightly fitted
- Ensure that the manual pull toggle is accessible

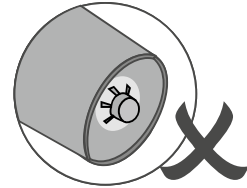
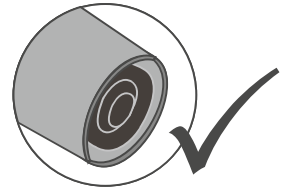

IF A RED INDICATOR SHOWS, CHECK THE FOLLOWING ITEMS:

- Ensure a fully charged cylinder is tightly fitted.
- Ensure an automatic capsule is tightly fitted (on Pro-Sensor Automatic)
- Check that the expiry date has not passed and check that there is a plate in the base of the capsule. If there is no plate and a red dot is visible the capsule has been fired and must not be used. See re-arming your lifejacket for how to fit a new capsule onto your operating mechanism.
- Ensure that the manual pull toggle is accessible.



AFTER USE (if Inflated)

- Rinse your lifejacket after use. (Refer to 'Cleaning & Storing Your Lifejacket')
- Re-arming your lifejacket. (Refer to 'Re-arming pro-sensor operating mechanisms')

PERIODICAL CHECKS

- A complete inspection of your lifejacket is to be carried out every three months.
- Check the fabric for cuts, tears, abrasion and signs of damage caused by heat.
- Leak testing is an important part of the periodical checks. Inflate your lifejacket orally until firm. Leave overnight or for a minimum of 12 hours. A lifejacket that is leaking will not hold its firmness and must be replaced. (Refer to 'Repacking the Crewfit 165N Sport')

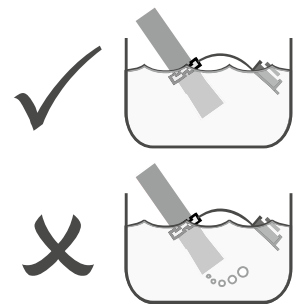

NOTE: Avoid wide variations in temperature when performing this test. Temperature variation can cause the inflatable chamber to lose firmness.

Examine the lifejacket for signs of damage, wear and tear or contamination. Pay particular attention to the webbings and the stitching on your lifejacket.

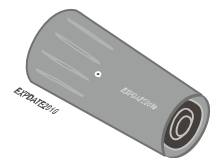

Perform the oral inflation valve test as follows:

- 1 Fully inflate the lifejacket
- 2 Place the oral tube into water and check for bubbles
- 3 If bubbles appear a replacement valve is required.

Check the expiry date on the automatic firing capsule. If it has expired it should be replaced.



WARNING: If you are not confident in self-inspection of your lifejacket using these instructions, refer to your closest Crewsaver approved service station for details. Crewsaver approved service stations can be found via our website: www.crewsaver.com



CLEANING & STORING YOUR LIFEJACKET

It is important that the lifejacket is stored in a dry, well-ventilated space. If the lifejacket is wet or damp, and it is fitted with an automatic firing capsule, it is advisable to remove the capsule until the lifejacket is completely dry. Any dampness in the lifejacket may penetrate the capsule and eventually cause it to operate the lifejacket. It is advisable to hang the lifejacket to dry on a coat hanger until it is completely dry before stowing. To avoid inflation, do not submerge the lifejacket in water unless the lifejacket has been used or the capsule has been removed.

Periodically rinse the lifejacket in fresh water, particularly if it has been in contact with salt water. Oil and similar marks should be removed by washing with warm soapy water.

Never put your lifejacket in a washing machine, spin or tumble dryer.

After washing always allow your lifejacket to dry naturally before stowing in a dry place.

OTHER IMPORTANT INFORMATION

Your new Crewfit has been tested to meet a temperature range between -10°C and 40°C as required by BS EN ISO 12402.

- When the temperature is well below freezing, your lifejacket may operate much slower than normal and at very low temperatures a fully discharged cylinder may not adequately inflate your lifejacket. In these temperatures the oral tube should be used for additional topping up if necessary.
- This lifejacket is not a PFD until fully inflated. Full performance may not be achieved using certain clothing or other circumstances. Certain circumstances will alter performance, such as waves or the wearing of garments which provide additional buoyancy. The buoyancy provided by the jacket can be affected if heavy objects are carried in the pockets.
- A whistle is located on the inside left inflation chamber. Six long blasts repeated at intervals is the international distress signal.

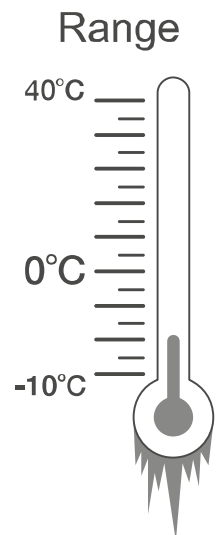

WARNING: Inflating your lifejacket using CO₂ inflation could over pressurise and damage your lifejacket if it has already been orally inflated fully. Do not use as a cushion or in any other way likely to cause damage.



WARNING: This lifejacket is inflated by a CO₂ gas cylinder. Gas cylinders are dangerous goods, and they must be kept away from children and not misused.

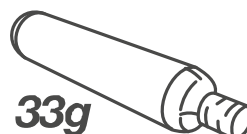

33g

**FOR USE WITH CREWFIT
165N SPORT LIFEJACKETS**

TESTING YOUR LIFEJACKET

Practice and training are required before use.

In an emergency, there is no time to learn how equipment works. Crewsaver recommend that you try your lifejacket to ascertain its performance before use in an emergency. This will also help familiarise yourself with the product.

When trying out your lifejacket, remember that you may need replacement parts or re-arming kits to get your lifejacket ready for use again.

If you are a weak swimmer it is strongly recommended that you use an automatically operated lifejacket or an inherently buoyant device.

Step 1: Put on your lifejacket by following the donning Instructions. (*Refer to 'Donning the Crewfit 165N Sport'*)

Step 2: Stand in shallow water or in a swimming pool, ensuring that the water is just deep enough for your head to be above the water's surface.

Step 3: Inflate your lifejacket. This can be done the following ways:

Automatically: If your lifejacket is an automatic it should fully inflate within five seconds of water contacting the automatic firing capsule. This activates the operating mechanism and releases the CO₂ cylinder into the lifejacket.

Manually: The lifejacket can be activated manually by a sharp downward pull on the toggle. The lifejacket should fully inflate within 5 seconds.

Oral Inflation: If you are using a pro-sensor automatic lifejacket ensure that the automatic firing capsule has been removed before entering the water. Open the lifejacket cover and locate the oral inflation tube, remove the cap and blow into the tube.

Once inflated see how the lifejacket holds you in the water, noting the position that it holds you in with your mouth well clear of the water's surface and your body at an angle.

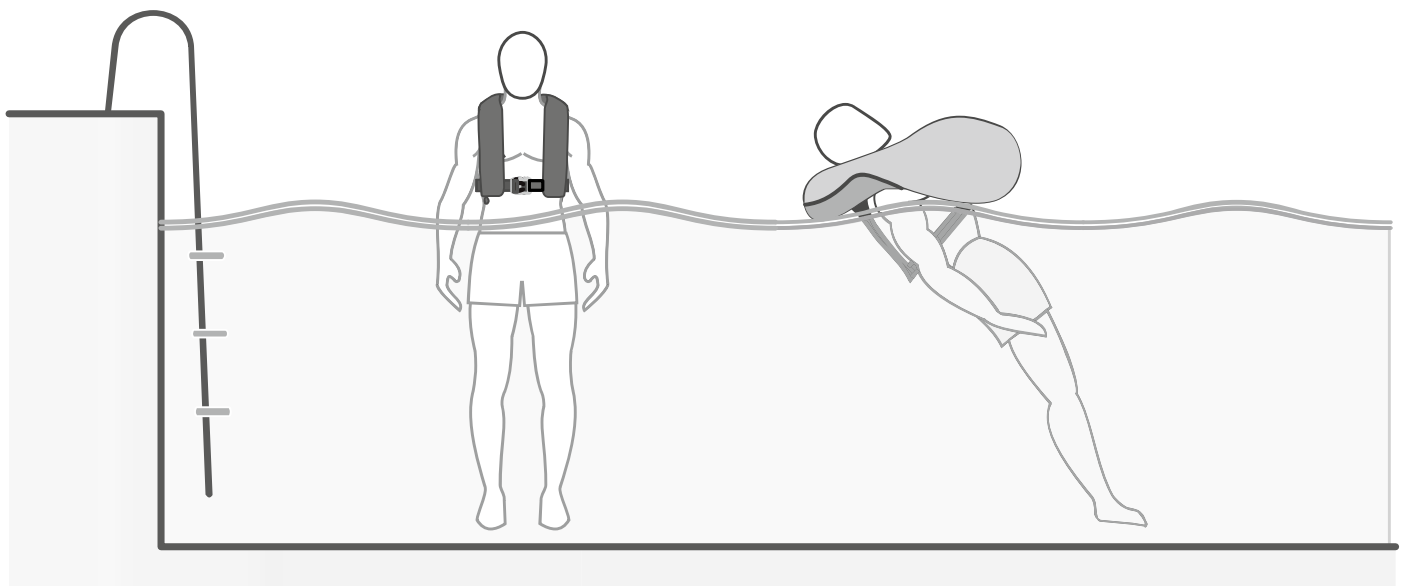

WARNING: Re-arm and re-pack your lifejacket following testing



TESTING YOUR LIFEJACKET

While in the water it is also recommended that you try out your lifejacket's spray hood.

- 1 Reach above your head and locate the grab loops on the spray hood. (Refer to 'Sprayhood and lifting becket')

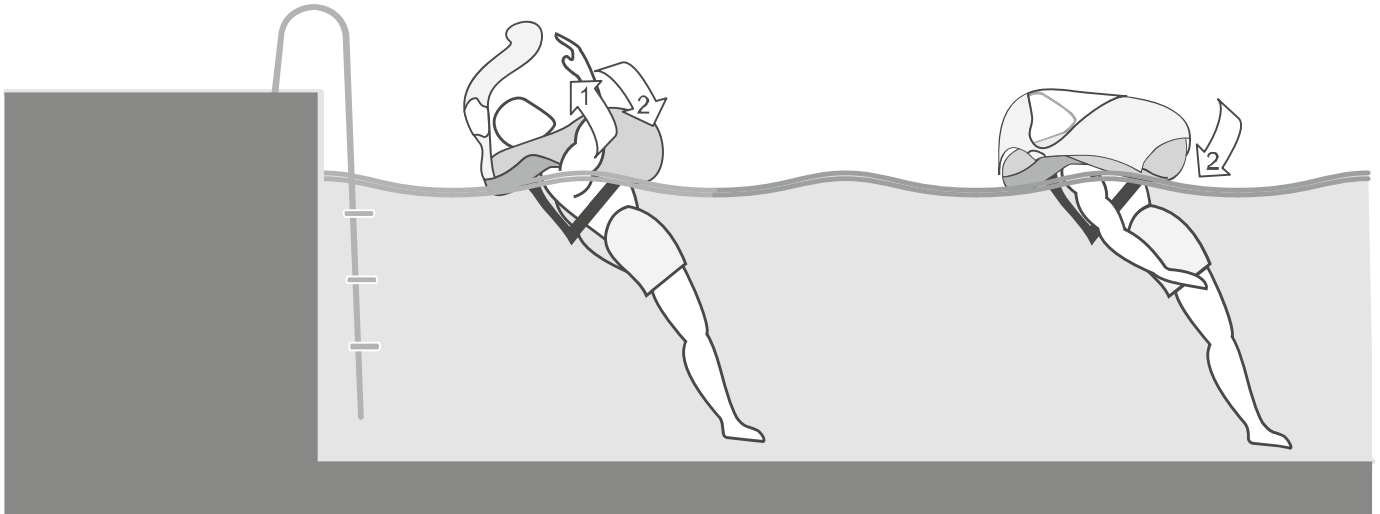

Your lifejacket should be tested whilst wearing any offshore clothing. Check that the lifejacket will turn you from a face down position to a face up position.

NOTE: Some offshore clothing in particular drysuits and immersion suits can trap air - this may affect the performance of the lifejacket.

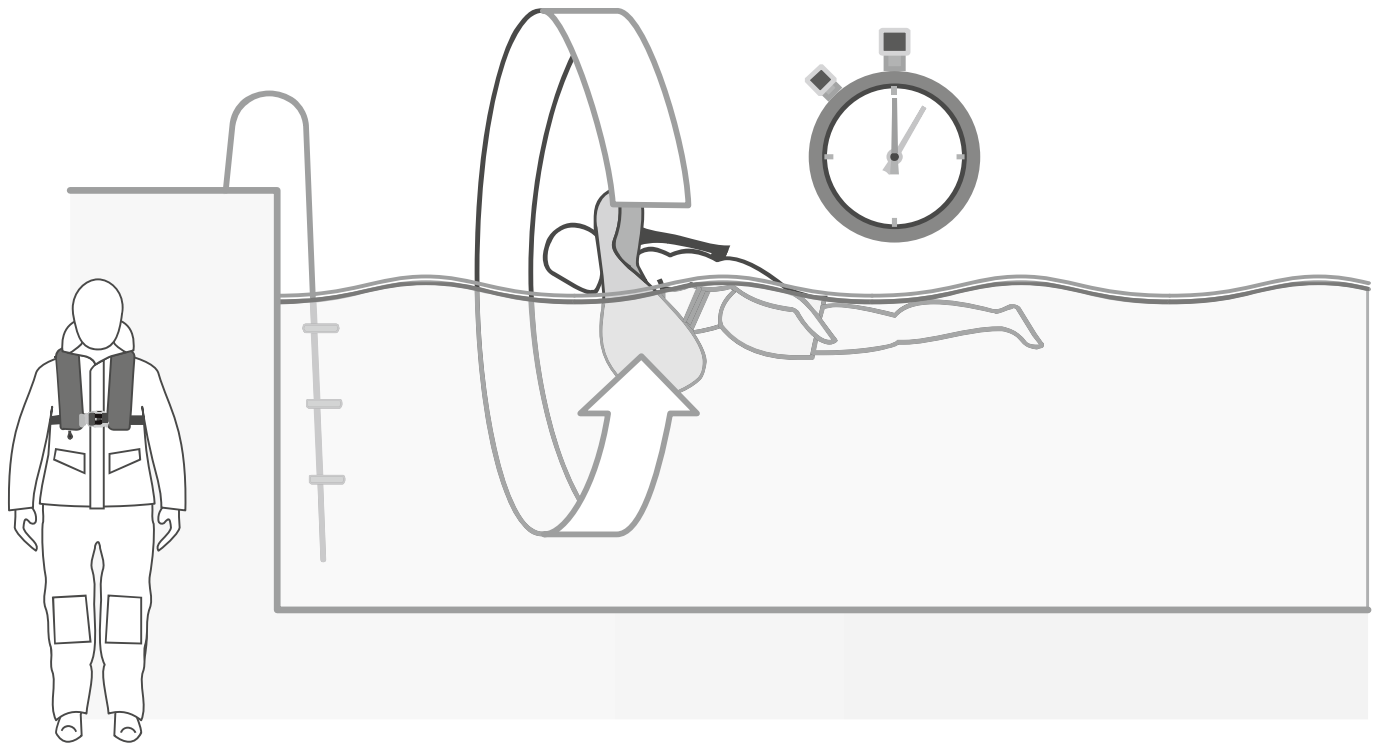

After testing your lifejacket completely deflate the lifejacket using the oral inflation tube. Let the lifejacket dry thoroughly. Do not expose to direct sunlight or heat. Re-arm your lifejacket following the relevant re-arm & re-pack instructions. (Refer to 'Rearming' and repacking instructions)

USING INFLATION TUBE ON INFLATABLE LIFEJACKETS

If required all inflatable lifejackets can be inflated orally without firing the CO₂ cylinder.



WARNING: Inflating your lifejacket using CO₂ inflation could over pressurize and damage your lifejacket if it has already been orally inflated fully.



INFLATING YOUR LIFEJACKET

- 1 Remove the valve cap (a) at the top of the inflation tube (b).
- 2 Blow into the inflation tube. The protective cover on the lifejacket will unfold as the inflation chamber takes shape. To make this easier open up the cover by hand and continue to blow into the tube until it is difficult to inflate further.
- 3 Ensure once inflated that you replace the valve cap (a). It is important to keep this in place, except when the deflation valve is being used.

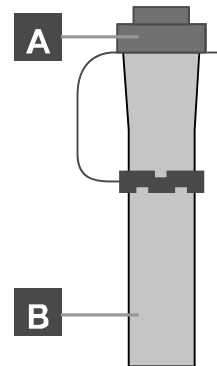

DEFLATING YOUR LIFEJACKET AFTER USE

- 1 Reverse the valve cap (a) at the top of the inflation tube and hold it in the valve.



WARNING: Do NOT use anything other than the valve cap to deflate your lifejacket. Any other item used may cause damage to the valve.



- 2 Squeeze the lifejacket to expel the air inside.



WARNING: If the lifejacket has been inflated using a gas cylinder take care not to inhale the expelled CO₂ gas.



- 3 When as much gas as possible has been expelled, re-inflate the lifejacket orally. This will reduce the concentration of any remaining CO₂.
- 4 Squeeze the lifejacket a second time expelling as much air as possible.
- 5 The lifejacket should now be completely deflated, and can be folded into the cover as before.
- 6 Replace the valve cap (b) back into the normal position on top of the inflation tube.



WARNING: Over inflation can damage your lifejacket.

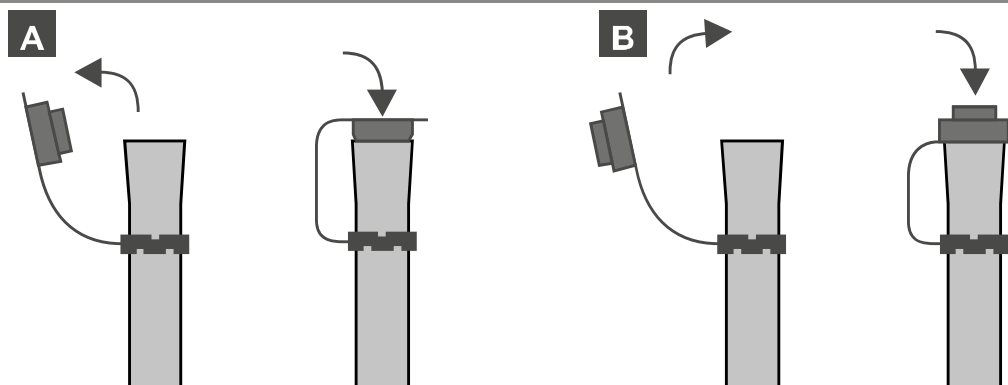

USING SAFETY LINES WITH A HARNESS LIFEJACKET

The Crewfit range of lifejackets can be used with all approved safety lines, on lifejackets with a harness.

Available within the Crewsaver range and suitable for use on the Crewfit 165N Sport are both 2 hook and 3 hook safety lines.

A 2 Hook Safety Line should be used when connected to a strong point on the boat; this will help to ensure you are attached securely in adverse conditions.

The 3 Hook Safety Line enables the transfer from one secure point on the boat to another, ensuring you remain safely attached at all times during the transfer.

CE ISO 12401
Deck safety Harness Class 1 0514



WARNING: The deck safety harness and safety line are intended to prevent the user falling overboard. They do not provide protection against falls from a height.



The deck safety harness and safety line may transmit very large forces. Only attach to strong hooking points or jack lines. Minimum strength of 1 tonne.

It is unsafe to wear this harness loose. The harness shall be worn tightly in order to be effective.



If your harness and/or safety line are subjected to an exceptional load while worn, it is vital that these are returned to Crewsaver for inspection, even if no external damage is visible.



Non harness version can be worn over a separate harness.

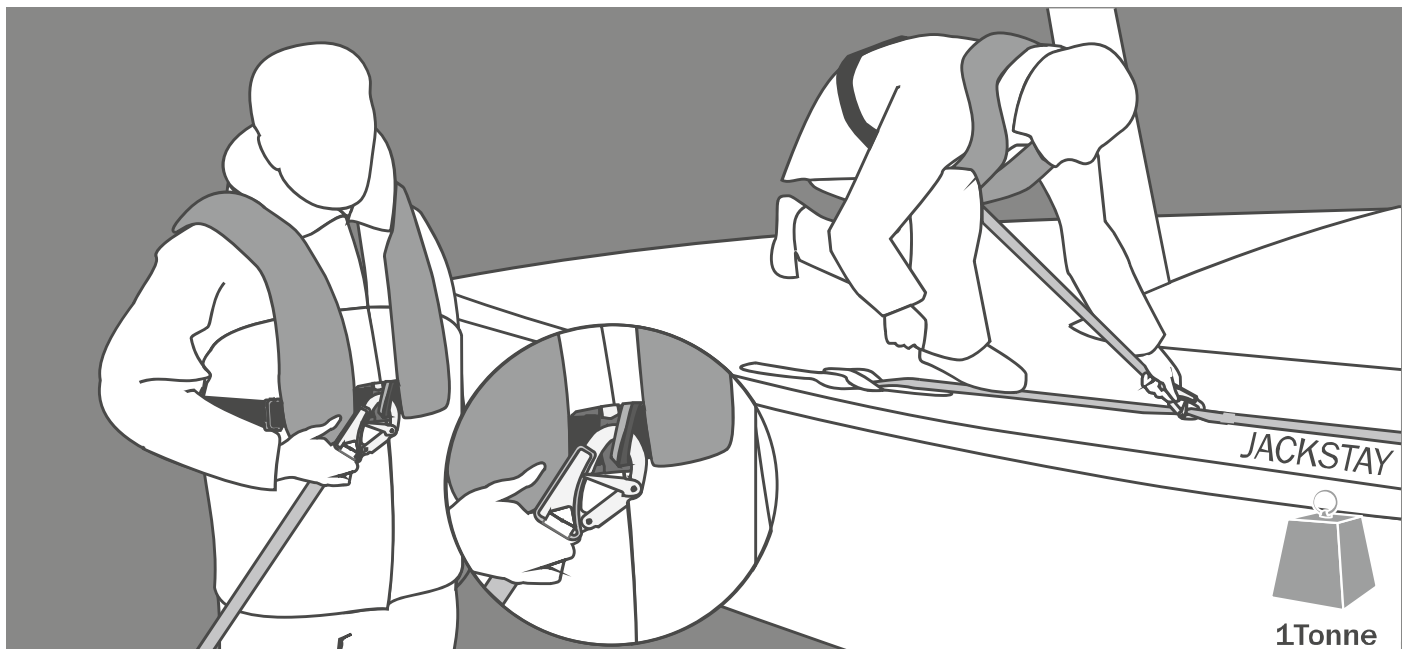

YOUR 3 YEAR GUARANTEE

Crewsaver has over 50 years' experience in manufacturing safety equipment and our total commitment to quality enables us to offer you a FULL 3 YEAR GUARANTEE on your lifejacket.

This 3 year guarantee includes all parts and labour to repair defective equipment and the return postage.

The guarantee covers all Crewsaver lifejackets and combined lifejackets/harnesses worn for normal leisure purposes. This excludes commercial and industrial use and other applications where equipment is either worn for prolonged periods or in severe conditions.

The guarantee does not cover the effects of accidental damage, normal wear and tear, or mistreatment, or where repairs have been carried out other than by a Crewsaver approved serviced centre.

The guarantee covers all lifejackets registered via the Crewsaver website, any products returned that are not registered with Crewsaver will not be considered for warranty.

Remember your lifejacket is an important piece of safety equipment and should be serviced annually. Servicing should be completed with genuine Crewsaver parts at a Crewsaver approved service station. Crewsaver will not accept any lifejackets for warranty that have not been serviced annually at a Crewsaver approved service station.

Please copy the Product Serial Number and Date Purchased below for your own reference:

SERIAL NO: 	DATE PURCHASED:
--------------------	-------------------------

For more information or to register your product please visit our website www.crewsaver.com

SERVICE ANNUALLY

Your lifejacket must be serviced on an annual basis.

Never try to repair a lifejacket yourself. You could cause more damage and render the lifejacket irreparable or affect the warranty.

Always return the lifejacket to a Crewsaver approved service station for repairs and servicing.

To find your nearest Crewsaver approved service station please visit: crewsaver.com/findastockist

Crewsaver, Survitec House, Lederle Lane, Gosport
Hampshire, PO13 0FZ, UNITED KINGDOM
Tel: +44 (0) 1329 8200 00
Fax: +44 (0) 1329 2362 18
For D Of C visit www.crewsaver.com

RFD (AUSTRALIA) PTY. LTD
PO BOX 61
SMITHFIELD NSW 2164, AUSTRALIA
Tel: +61 (2) 8797 4338



APPROVAL BY:
SGS FIMKO OY
TAKOMOTIE 8
00380 HELSINKI

