

# Exalto

WIPER TECHNOLOGIES

WIPER SYSTEMS

## Exalto wiper Controller for one HD/MD wiper

ITEM NO. 210341 / 210341P



CLEARLY  
THE BEST



## Contents

### 1. General

- 1.1 functions
- 1.2 general description
- 1.3 power supply
- 1.4 technical specifications
- 1.5 declaration of conformity

### 2. Installation

- 2.1 dimensions
- 2.2 installation

### 3. Electric connections

- 3.1 general lay out
- 3.2 wiring diagram

### 4. Operation

- 4.1 functions of the push buttons
- 4.2 on/off switching
- 4.3 increase speed - decrease speed - intermittent mode selection
- 4.4 signal mode
- 4.5 wipe/wash program

### 5. Failure

- 5.1 continuous flashing signal
- 5.2 reset function

### 6. Available models



# 1. General

## 1.1 Functions



Brief explanation of buttons and LED's Please see section 4 for complete operating instructions.

Pos. Function

- 1 Main ON/OFF switch/wipe-wash program.
- 2 Increase speed/decrease time between strokes.
- 3 Decrease speed/increase time between strokes.

## 1.2 General description

The 210341 is a micro-controller based intelligent switch for operating one Exalto HD/MD wiper motor. It provides all the functions for a proper windscreen cleaning. It consists of a touch pad with 45 cm (17") connection cable.

This wiper control offers:

- two continuous speeds
- three intermittent speeds
- perfect self parking due to dynamic brake
- wipe/wash program
- dimmer input

Visual indications for:

- ON
- continuous and intermittent modes

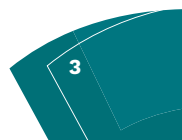



## MANUAL WIPER SYSTEMS

### 1.3 Power supply

This wiper control is available to operate under a power supply of 12 or 24V DC. Check the power supply of the unit supplied, before connecting it to the ship's electric system.

### 1.4 Technical specifications

Model	210341
Wiper motor	223 / 232 / 235-series
Voltage	10V to 30V DC
Internal fuse	4 Amp, self-resettable PTC
Stand-by current	less than 20 mA
Protection	polarity inversion
Motor - output current	low or high speed - 4 Amps max.
Input	1 parking switch (open in park protection) dimmer (connect to + if not used)
Output	1 low speed - LOW 1 high speed - HIGH 1 wash pump (positive pole)
Functions	3 intermittent speed setting 2 continuous speeds (low and high speed) wash / wipe program
Connections	10 poles connector
Case	ABS black
Working temperature	-10 °C / +50 °C
Storage temperature	-20 °C / +70 °C



Model		210341P
Wiper motor	240 / 255 / 285 BS-series	
Voltage	10V to 30V DC	
Internal fuse	12 Amps PTC	
Stand-by current	less than 20 mA	
Protection	polarity inversion	
Motor - output current	low or high speed - 12 Amps max.	
Input	1 parking switch (open in park protection) dimmer (connect to + if not used)	
Output	1 low speed - LOW 1 high speed - HIGH 1 wash pump (positive pole)	
Functions	3 intermittent speed setting 2 continuous speeds (low and high speed) wash / wipe program	
Connections	<b>relay box</b>	<b>console</b>
	1 seven poles connector 1 eight poles tel. connector	1 four poles minifit connector 1 eight poles tel. connector
Case	ABS black	
Working temperature	-10 °C / +50 °C	
Storage temperature	-20 °C / +70 °C	





## MANUAL WIPER SYSTEMS

### 1.5 Declaration of conformity

This wiper control is in conformity at requisition of electromagnetic compatibility and of security with directives, 2014/30/EU (EMC) and 2011/65/EC (RoHS)

Harmonize norms apply:

- CEI EN 60945 ed 2003 + IEC 2018-04: MARITIME NAVIGATION EQUIPMENT AND SYSTEMS
- EN 50581 ed 2012: RoHS

Supplementary information:

- The European directive 2014/35/EU (Low Voltage) is not applicable to this product as this device is powered by voltage values below 50Vac or 75Vdc.
- The cabling systems that will be installed on the product, should be conform their own safety requirements. The system complied with the requirements of IMO A.813 Decision about protection against interference on maritime radio communications.



## 2. Installation

### 2.1 Dimensions

All dimensions in mm.

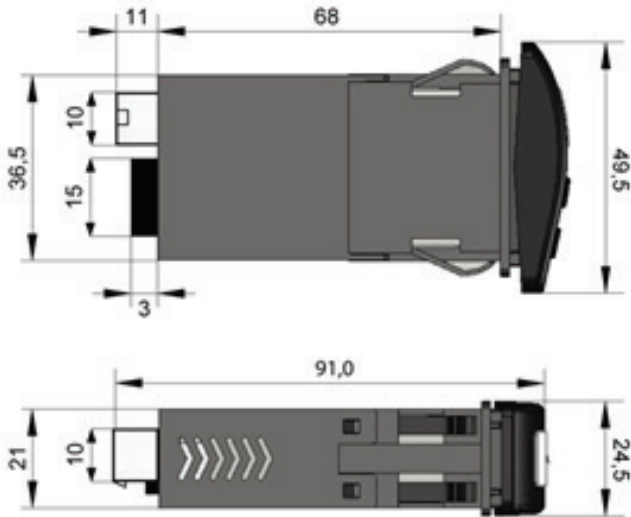

Dimensions relaybox in mm (only for the 210341P version).

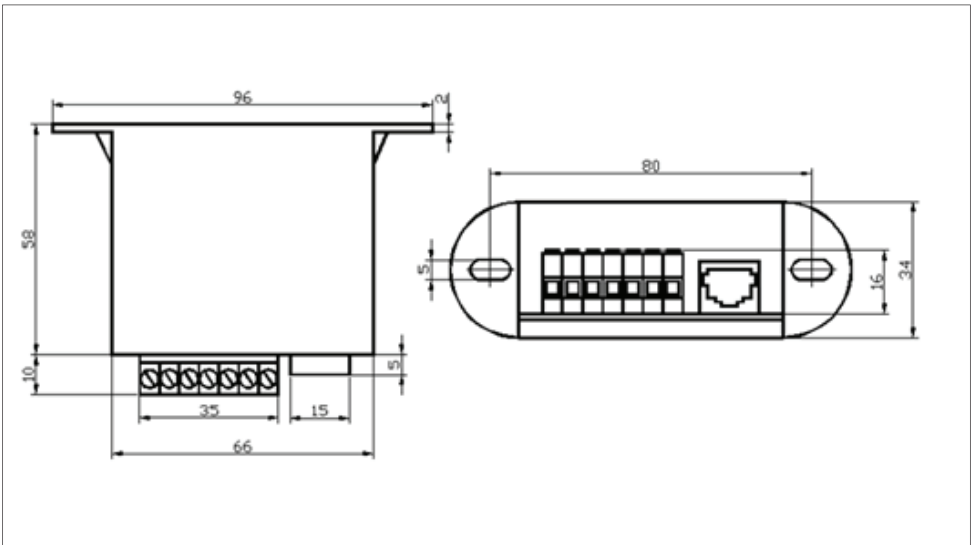



## MANUAL WIPER SYSTEMS

### 2.2 Installation

The touch pad is to be fitted at a location that is within suitable reach to allow for ease of operation. Make sure that sufficient room is available for the cables and the connectors. The required mounting hole for the touch pad is 36.5 x 21 mm. There should be at least 100 mm space available under the front of the touch pad for the connection cable and plug.

### Important

Protect the power supply line(s) by a thermal/magnetic circuit breaker. Thermal/magnetic circuit breaker and cables diameter must be sized according to the motor consumption and the regulations. Please make sure you insert the connector (linked to the wiper motor) before connecting the power supply!





### 3. Electric connections

#### 3.1 General switch plug lay out

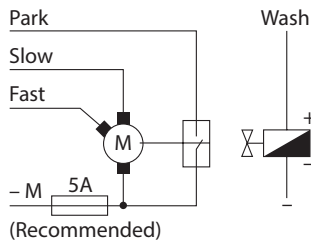
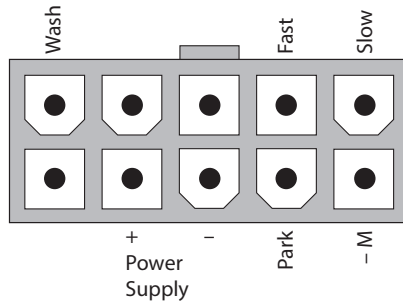



## MANUAL WIPER SYSTEMS

### 3.2 Wiring diagram

Colour coding for wiper motor.

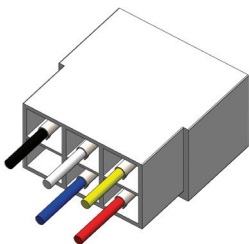

Function	Polarity	Motorcode	Switch code	Cable
High speed	+	53b	H	White
Low speed	+	53	L	Yellow
Negative	-	31		Black
Stop - self park		31b	P	Blue
Positive	+	53a	B	Red

Colour code and connection of wiring coming from the 210341 controller:

- Green is to be connected to the Positive (53a) of the motor wire.
- Blue is to be connected to the Negative (31) and Stop/Self Park (31b) of the motor wire.
- Yellow is to be connected to the Low Speed (53) of the motor wire.
- White is to be connected to the High Speed (53b) of the motor wire.
- Brown is to be connected to a pump or solenoid.

Always refer to the User Manual as supplied with the Exalto Wiper before connecting the Exalto wiper to the wiper switch.



Connections to relay box (only the 210341P version)

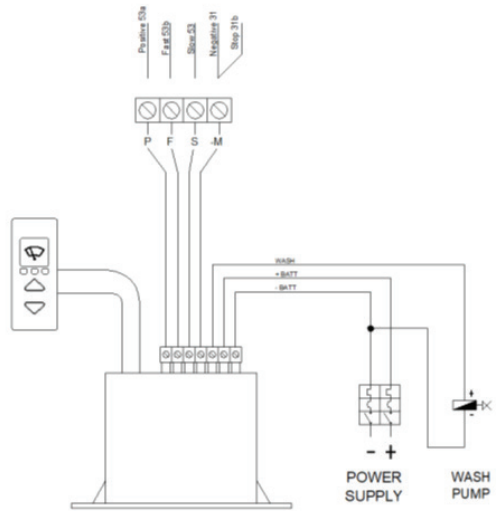
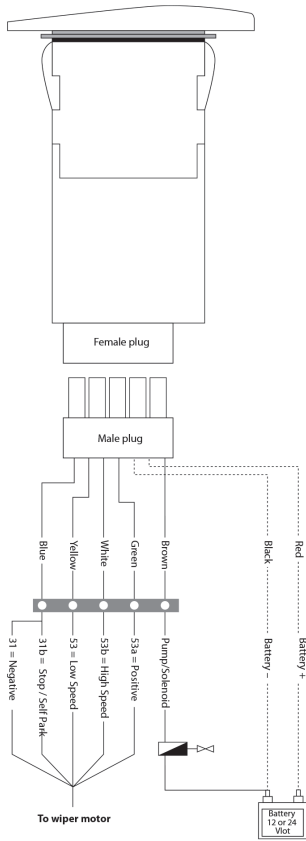



## MANUAL WIPER SYSTEMS

### 4. Operation

#### 4.1 Functions of the push buttons

All push buttons have a double function as described in the chart (see paragraph 4.4).

#### 4.2 ON/OFF switching

By pressing and releasing button 1 or 2, the wiper can be switched ON or OFF.

#### 4.3 Increase speed - decrease speed - intermittent mode selection

The wiper motor starts in SLOW speed mode (the only possible continuous mode if one speed-motor is used).

By pressing button 2, the motor will power FAST SPEED.

By pressing button 3, you can step down through the speed modes:

- LOW SPEED - 2 SEC. INTERMITTENT - 4 SEC. INTERMITTENT - 8 SEC. INTERMITTENT.

By pressing button 2 you can step up through the speed modes.

#### 4.4 Signals mode

The three LED's shows the controller operation setting. By pressing any button, the mode will change. The LEDS will flash as many times as the delay times (in seconds) between the wiper strokes (if 4 seconds is the delay times between the wiper strokes, the LED will flash 4 times) or the LED's will have a light flash (slowly when SLOW speed is selected and quickly when FAST speed is selected).

Mode	LED ( <input type="checkbox"/> = on )	Signal
FAST speed	<input type="checkbox"/> <input type="checkbox"/> <input type="checkbox"/>	Fast slight blink
SLOW speed	<input type="checkbox"/> <input type="checkbox"/> <input checked="" type="checkbox"/>	Slow slight blink
2 sec. delay	<input checked="" type="checkbox"/> <input checked="" type="checkbox"/> <input type="checkbox"/>	2 slow blink
4 sec. delay	<input checked="" type="checkbox"/> <input type="checkbox"/> <input checked="" type="checkbox"/>	4 slow blink
8 sec. delay	<input type="checkbox"/> <input checked="" type="checkbox"/> <input checked="" type="checkbox"/>	8 slow blink
OFF	<input checked="" type="checkbox"/> <input checked="" type="checkbox"/> <input checked="" type="checkbox"/>	LED's OFF
Wipe/wash	<input type="checkbox"/> <input checked="" type="checkbox"/> <input type="checkbox"/>	
Failure	Asymm.	Continuous flashing signal



## 4.5 Wipe/wash program

This wiper control has a built-in 'smart' wipe/wash program. The program is as shown below. By keeping button 1 pressed for more than one second, the Wipe/wash program will be activated. After the Wipe/wash program has ended, the wiper will return to the wipe setting that was previously used.

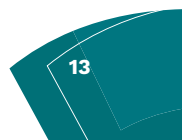
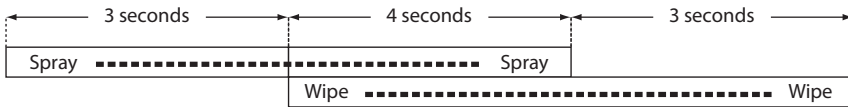



### 5. Failure

#### 5.1 Continuous flashing signal

A continuous flashing signal indicates that the 210341 does not receive a parking switch signal. This may occur if:

- parking switch is damaged or disconnected;
- motor does not run (damaged or disconnected);
- 10-pin connector has been inserted after power supply and control works as with one speed motor.
- 10-pin connector lead could be damaged.

#### 5.2 Reset function

With any failure it is important you first perform a reset process to the control system:

- turn power off to the wiper controller
- remove the 10-pin connector from the back of the console
- inspect that all terminals are located correctly and in position
- make sure the motor is connected correctly to the console
- wait 30 seconds
- reconnect the 10-pin connector to the back of the console
- turn power on
- test operation of the wiper controller
- if problems continues, check notes on section 5.1



### 6. Available models

- 210341 - Wiper controller for 1 wiper, max 4mA
- 210341J - Wiper controller for 1 wiper, max 6mA
- 210341P - Wiper controller for 1 wiper, max 12mA
- 210341.GRDIM - Wiper controller for 1 wiper, max 4mA, green leds
- 210341-1 - Wiper controller for 1 wiper, max 4 mA, 1 intermittent speed



**CLEARLY  
THE BEST**

**Exalto Wiper Technologies**  
Nijverheidsstraat 12  
3371 XE Hardinxveld-Giessendam  
The Netherlands

+31 (0)184 615 800  
wipers@exalto.com

**[exaltowipers.com](https://www.exaltowipers.com)**

Version 01-2022