



# YachtSense™ Link

Marine 4G Router

---

## INSTALLATION & OPERATION INSTRUCTIONS

English (en-US)

Date: 06-2022

Document number: 81397 (Rev 5)

© 2022 Raymarine UK Limited

**Raymarine®**



## Trademark and patents notice

**Raymarine, Tacktick, Clear Pulse, Truzoom, SeaTalk, SeaTalk<sup>hs</sup>, SeaTalkng**, and **Micronet**, are registered or claimed trademarks of Raymarine Belgium.

**FLIR, YachtSense, DockSense, LightHouse, RangeFusion, DownVision, SideVision, RealVision, HyperVision, Dragonfly, Element, Quantum, Axiom, Instalert, Infrared Everywhere, The World's Sixth Sense** and **ClearCruise** are registered or claimed trademarks of FLIR Systems, Inc.

All other trademarks, trade names, or company names referenced herein are used for identification only and are the property of their respective owners.

This product is protected by patents, design patents, patents pending, or design patents pending.

## Fair Use Statement

You may print no more than three copies of this manual for your own use. You may not make any further copies or distribute or use the manual in any other way including without limitation exploiting the manual commercially or giving or selling copies to third parties.

## Software updates



Check the Raymarine website for the latest software releases for your product.

[www.raymarine.com/software](http://www.raymarine.com/software)

## Product documentation



The latest versions of all English and translated documents are available to download in PDF format from the website:

[www.raymarine.com/manuals](http://www.raymarine.com/manuals).

Please check the website to ensure you have the latest documentation.

## Non-Controlled information

### Important:

This document does not contain export-controlled information.

## Publication copyright

**Copyright ©2022 Raymarine UK Ltd. All rights reserved. No parts of this material may be copied, translated, or transmitted (in any medium) without the prior written permission of Raymarine UK Ltd.**



# CONTENTS

<b>CHAPTER 1 IMPORTANT INFORMATION .....</b>	<b>9</b>		
Disclaimer .....	9		
Product modifications .....	9		
RF exposure .....	9		
5 GHz Wi-Fi band.....	9		
Compliance Statement (Part 15.19) .....	10		
FCC Interference Statement (Part 15.105 (b)).....	10		
Innovation, Science and Economic Development Canada (ISED) .....	10		
Innovation, Sciences et Développement économique Canada (Français) .....	10		
Declaration of Conformity .....	10		
IMO and SOLAS .....	10		
YachtSense Link router account transfer / ownership transfer .....	11		
Product disposal .....	11		
Warranty registration.....	11		
Technical accuracy .....	11		
<b>CHAPTER 2 DOCUMENT AND PRODUCT INFORMATION .....</b>	<b>12</b>		
2.1 Product documentation .....	13		
Document illustrations .....	13		
2.2 Product overview .....	13		
YachtSense Link system diagram .....	14		
Third party hardware with companion apps .....	14		
2.3 Parts supplied .....	14		
<b>CHAPTER 3 YACHTSENSE ECOSYSTEM .....</b>	<b>16</b>		
3.1 YachtSense ecosystem .....	17		
3.2 On boat features.....	17		
3.3 Off boat premium features .....	19		
3.4 Raymarine app .....	19		
How to connect guide .....	19		
Connect to a chartplotter directly .....	19		
Display mirroring (view and control).....	19		
Transferring LightHouse charts.....	20		
Chartplotter file transfer .....	20		
Connect to your YachtSense Link router .....	20		
Geofencing.....	21		
Data view and channel control.....	21		
User access management.....	22		
Boat alerts.....	22		
Boat systems .....	22		
3.5 Removing a boat system.....	22		
3.6 Removing a router .....	22		
3.7 YachtSense Link router account transfer / ownership transfer .....	23		
<b>CHAPTER 4 INSTALLATION .....</b>	<b>24</b>		
4.1 Tools required .....	25		
4.2 Selecting a location.....	25		
Warnings and cautions .....	25		
YachtSense™ Link location requirements.....	25		

Wireless location requirements for optimum performance .....	25	5.6 Power connection.....	36
Mounting surface requirements.....	26	In-line fuse and thermal breaker ratings.....	37
Cable routing requirements.....	26	Power distribution.....	37
Electrical interference .....	26	5.7 Grounding connection .....	39
Power supply.....	26	5.8 5-in-1 antenna connections .....	40
RF interference .....	27	Antenna extension kit.....	41
Compass safe distance .....	27	5.9 Boat Wi-Fi antenna connections .....	41
EMC installation guidelines.....	27	5.10 RayNet connections .....	42
Suppression ferrites.....	27	5.11 Third party hardware with companion apps .....	42
Connections to other equipment .....	28	5.12 SeaTalkng connection.....	42
5-in-1 antenna location requirements .....	28	5.13 Input and output channels .....	43
4.3 YachtSense™ Link product dimensions .....	28	5.14 Input channel connection wiring .....	43
4.4 5-in-1 antenna dimensions.....	29	Input channel connections.....	43
4.5 Inserting SIM cards.....	29	5.15 Output channel wiring .....	44
4.6 Mounting the YachtSense™ Link.....	31	Output channel connections.....	45
4.7 Mounting the 5-in-1 antenna .....	32	<b>CHAPTER 6 OPERATIONS .....</b>	<b>46</b>
<b>CHAPTER 5 CONNECTIONS .....</b>	<b>33</b>	6.1 Getting started .....	47
5.1 General cabling guidance .....	34	Accessing the web interface from a Raymarine MFD.....	47
Cable types and length .....	34	Accessing the web interface using a wired connection.....	47
Strain relief .....	34	Accessing the web interface using a Wi-Fi connection.....	48
Cable shielding.....	34	Accessing settings pages.....	49
Connecting cables .....	34	Configuring mobile data .....	49
5.2 YachtSense Link system diagram .....	34	Connecting to an available Wi-Fi network.....	50
5.3 Connections overview.....	35		
5.4 MFD connections .....	35		
5.5 YachtSense ecosystem .....	36		

Connecting to a Wi-Fi network manually .....	50	Output channel configuration.....	57
Forgetting a saved Wi-Fi network.....	50	Alert notifications page .....	57
Setting up the router's access point .....	50	Power management page.....	57
Network security.....	51	Performing a router software upgrade.....	58
Connecting an Android device to the router's access point.....	51	Restart & factory reset.....	58
Connecting an iOS device to the router's Wi-Fi access point.....	52	Performing a factory reset to restore default settings .....	58
6.2 Link your router (Onboarding).....	52	Performing a factory reset prior to disposal / change of ownership or account.....	58
6.3 Status page.....	53	Changing the admin password .....	59
6.4 Basic settings.....	53	6.7 Help .....	59
Wi-Fi connection page.....	53	6.8 YachtSense Link router account transfer / ownership transfer .....	59
Mobile data & SIM management page.....	53	6.9 Boat system and router removal (Offboarding).....	59
Access point page.....	54	Removing a boat system .....	59
Info page .....	55	Removing a router.....	60
6.5 Connected devices page.....	55	<b>CHAPTER 7 TROUBLESHOOTING .....</b>	<b>61</b>
6.6 Advanced settings.....	55	7.1 Troubleshooting.....	62
LAN set-up.....	55	7.2 LED diagnostics .....	62
Ethernet configuration page .....	55	7.3 Power up troubleshooting .....	63
Wi-Fi configuration page.....	56	7.4 Wi-Fi troubleshooting.....	64
IPv6 page .....	56	7.5 Web interface access troubleshooting.....	65
GNSS page.....	56	7.6 Mobile / cellular data troubleshooting .....	65
Inputs and outputs .....	56	7.7 Password reset (forgotten password).....	66
Input channel monitoring.....	56	7.8 Performing a network settings reset .....	67
Input channel configuration.....	56	7.9 Performing a hard reset.....	67
Output channel control.....	56		

<b>CHAPTER 8 MAINTENANCE</b> .....	<b>68</b>
8.1 Service and maintenance .....	69
Routine equipment checks .....	69
8.2 Product cleaning .....	69
8.3 Product returns.....	69
<b>CHAPTER 9 TECHNICAL SUPPORT</b> .....	<b>70</b>
9.1 Raymarine product support and servicing.....	71
9.2 Frequently Asked Questions (FAQs) .....	72
9.3 Learning resources.....	72
9.4 Product returns .....	72
<b>CHAPTER 10 TECHNICAL SPECIFICATION</b> .....	<b>73</b>
10.1 YachtSense Link technical specification.....	74
Power specification.....	74
Environmental specification .....	74
Physical specification .....	74
Wireless networks specification .....	74
<b>CHAPTER 11 SPARES AND ACCESSORIES</b> .....	<b>75</b>
11.1 Spares and Accessories .....	76
11.2 RayNet to RayNet cables and connectors.....	77
11.3 RayNet to RJ45 adapter cables .....	78
11.4 SeaTalkng <sup>®</sup> cables and accessories.....	80
<b>APPENDIX A NMEA 2000 PGN SUPPORT</b> .....	<b>85</b>
<b>APPENDIX B DOCUMENT CHANGE HISTORY</b> .....	<b>86</b>



# CHAPTER 1: IMPORTANT INFORMATION



## Warning: Product installation and operation

- This product must be installed and operated in accordance with the instructions provided. Failure to do so could result in personal injury, damage to your vessel and/or poor product performance.
- Raymarine highly recommends certified installation by a Raymarine approved installer. A certified installation qualifies for enhanced product warranty benefits. Register your warranty on the Raymarine website: [www.raymarine.com/warranty](http://www.raymarine.com/warranty)



## Warning: High voltage

This product contains high voltage. Adjustments require specialized service procedures and tools only available to qualified service technicians. There are no user serviceable parts or adjustments. The operator should never remove the cover or attempt to service the product.



## Warning: Input and output channels

- The router's input and output channels enable creation of a simple digital monitoring / control system. As device connections are outside of Raymarine's control the company will not be held liable for damage or injury caused due to incorrect connections.
- Input and output device connections should only be carried out by a competent person familiar with vessel digital switching systems.
- The Router's output channels are rated at 200 mA and are only intended to be connected to devices via standard automotive relays.
- If in any doubt or for further advice please contact Raymarine Technical Support.



## Warning: Potential ignition source

This product is NOT approved for use in hazardous/flammable atmospheres. Do NOT install in a hazardous/flammable atmosphere (such as in an engine room or near fuel tanks).

## Disclaimer

Raymarine does not warrant that this product is error-free or that it is compatible with products manufactured by any person or entity other than Raymarine.

Raymarine is not responsible for damages or injuries caused by your use or inability to use the product, by the interaction of the product with products manufactured by others, or by errors in information utilized by the product supplied by third parties.

## Product modifications

Changes or modifications not expressly approved by the party responsible for compliance could void the user's authority to operate the equipment.

## RF exposure

To be protected against all verified adverse effects, the separation distance of at least 0.5 m (1.64 ft) must be maintained between the antenna of the radio having maximum 5.84 dBi antenna gain and all persons.

## 5 GHz Wi-Fi band

The band 5150 MHz to 5350 MHz for this device is restricted to indoor use only within all European Union countries.

## Compliance Statement (Part 15.19)

This device complies with Part 15 of the FCC Rules. Operation is subject to the following two conditions:

1. This device may not cause harmful interference.
2. This device must accept any interference received, including interference that may cause undesired operation.

## FCC Interference Statement (Part 15.105 (b))

This equipment has been tested and found to comply with the limits for a Class B digital device, pursuant to Part 15 of the FCC Rules.

These limits are designed to provide reasonable protection against harmful interference in a residential installation. This equipment generates, uses, and can radiate radio frequency energy and, if not installed and used in accordance with the instructions, may cause harmful interference to radio communications. However, there is no guarantee that interference will not occur in a particular installation. If this equipment does cause harmful interference to radio or television reception, which can be determined by turning the equipment off and on, the user is encouraged to try to correct the interference by one of the following measures:

1. Reorient or relocate the receiving antenna.
2. Increase the separation between the equipment and receiver.
3. Connect the equipment into an outlet on a circuit different from that to which the receiver is connected.
4. Consult the dealer or an experienced radio / TV technician for help.

## Innovation, Science and Economic Development Canada (ISED)

This device complies with License-exempt RSS standard(s).

Operation is subject to the following two conditions:

1. This device may not cause interference; and

2. This device must accept any interference, including interference that may cause undesired operation of the device.

This Class B digital apparatus complies with Canadian ICES-003.

## Innovation, Sciences et Développement économique Canada (Français)

Cet appareil est conforme aux normes d'exemption de licence RSS.

Son fonctionnement est soumis aux deux conditions suivantes:

1. cet appareil ne doit pas causer d'interférence, et
2. cet appareil doit accepter toute interférence, notamment les interférences qui peuvent affecter son fonctionnement.

Cet appareil numérique de la classe B est conforme à la norme NMB-003 du Canada.

## Declaration of Conformity

FLIR Belgium BVBA declares that the following radio equipment type product is in compliance with the Radio Equipment Directive 2014/53/EU:

- YachtSense™ **Link Marine Cloud Router** — E70640

The original Declaration of Conformity certificate may be viewed on the relevant product page at [www.raymarine.com/manuals](http://www.raymarine.com/manuals).

## IMO and SOLAS

The equipment described within this document is intended for use on leisure marine boats and workboats NOT covered by International Maritime Organization (IMO) and Safety of Life at Sea (SOLAS) Carriage Regulations.

## YachtSense Link router account transfer / ownership transfer

Yachtsense Link routers can only be linked to one account at a time.

To link the router to a different account it must first be removed from the existing account (“Offboarding”). For instructions refer to: [p.22 – Removing a router](#)

### **Attempts to link to a router that is already linked to an account will fail.**

If you receive a message when trying to link to your router that states it is already assigned to another account, you will need to contact the previous owner and ask them to remove the router from their account.

If you cannot contact the previous owner, Raymarine technical support may be able to contact them on your behalf.

In most cases if the previous owner cannot be reached or is unwilling to remove the router from their account, it will NOT be possible for you to link your router.

If you purchased the router new, via either a third party reseller or as a refurbished unit, and you receive a message that your router is already assigned to an account, you should return it to the seller for a refund or exchange and let them know that it is already linked to another account.

## Product disposal

Dispose of this product in accordance with the WEEE Directive.

The Waste Electrical and Electronic Equipment (WEEE) Directive requires the recycling of waste electrical and electronic equipment which contains materials, components and substances that may be hazardous and present a risk to human health and the environment when WEEE is not handled correctly.



Equipment marked with the crossed-out wheeled bin symbol indicates that the equipment should not be disposed of in unsorted household waste. Local authorities in many regions have established collection schemes under which residents can dispose of waste electrical and electronic equipment at a recycling center or other collection point. For more information about suitable collection points for waste electrical and electronic equipment in your region, refer to the Raymarine website: [www.raymarine.eu/recycling](http://www.raymarine.eu/recycling).

## Warranty registration

To register your Raymarine product ownership, please visit [www.raymarine.com](http://www.raymarine.com) and register online.

It is important that you register your product to receive full warranty benefits. Your unit package includes a bar code label indicating the serial number of the unit. You will need this serial number when registering your product online. You should retain the label for future reference.

## Technical accuracy

To the best of our knowledge, the information in this document was correct at the time it was produced. However, Raymarine cannot accept liability for any inaccuracies or omissions it may contain. In addition, our policy of continuous product improvement may change specifications without notice. As a result, Raymarine cannot accept liability for any differences between the product and this document. Please check the Raymarine website ([www.raymarine.com](http://www.raymarine.com)) to ensure you have the most up-to-date version(s) of the documentation for your product.

# CHAPTER 2: DOCUMENT AND PRODUCT INFORMATION

## CHAPTER CONTENTS

- 2.1 Product documentation — page 13
- 2.2 Product overview — page 13
- 2.3 Parts supplied — page 14

## 2.1 Product documentation

The following documentation is applicable to your product:

This and other Raymarine product documents are available to download in PDF format from [www.raymarine.com](http://www.raymarine.com).

- 81397 — YachtSense™ Link Marine Cloud Router Installation and operation instructions (This document)
- 87408 — YachtSense™ Link Marine Cloud Router Mounting Template

## Document illustrations

Your product and if applicable, its user interface may differ slightly from that shown in the illustrations in this document, depending on product variant and date of manufacture.

All images are provided for illustration purposes only.

## 2.2 Product overview

The YachtSense™ Link Marine Cloud Router (part number E70640) is a 4G smart router that provides a Wi-Fi hotspot and/or Ethernet internet connection to other devices on your vessel, and also enables remote monitoring and control of compatible onboard systems from a wireless device using Wireless or cellular (2G/3G/4G) data networks.

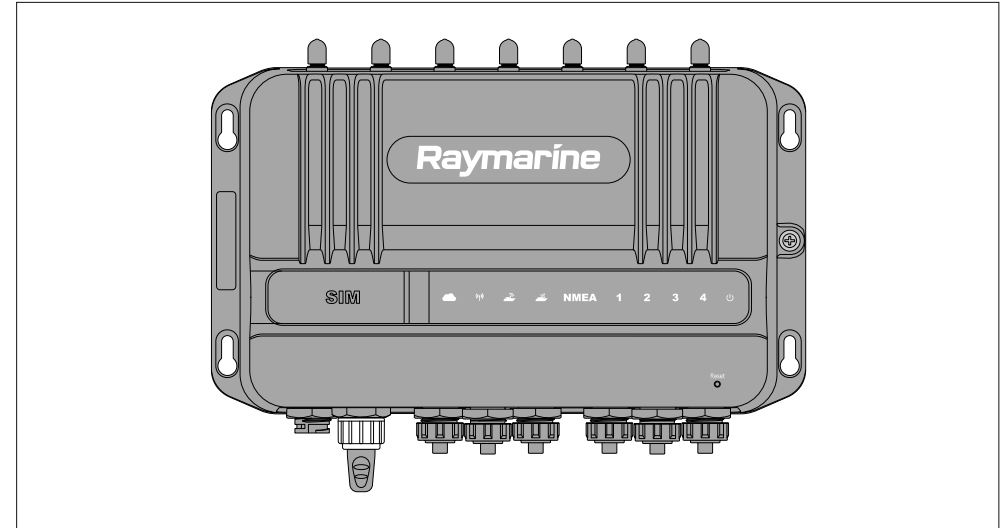

The YachtSense™ Link Marine Cloud Router includes the following features:

- Dual Micro-SIM card slots.
- Cellular antenna connections.
- Diversity antenna connections.
- Dual Wi-Fi network (DOCK WLAN) for off boat wireless connections.
- Dual Wi-Fi network (BOAT Wi-Fi) for onboard wireless connections.
- Built in GNSS (GPS) receiver (GLONASS and Beidou compatible).
- 4 digital input channels, for device monitoring.
- 4 digital output channels (rated at 200 mA), for device control.
- 4 RayNet (SeaTalkhs®) network ports.
- SeaTalkng® / NMEA 2000 connection.
- Web browser user interface for configuration.
- NAT firewall

- Compatible with Raymarine MFDs running LightHouse™ version 4.0 and above.

## YachtSense Link system diagram

The following diagram provides an overview of a typical system, including the available connections and the types of devices that can be connected to your router.

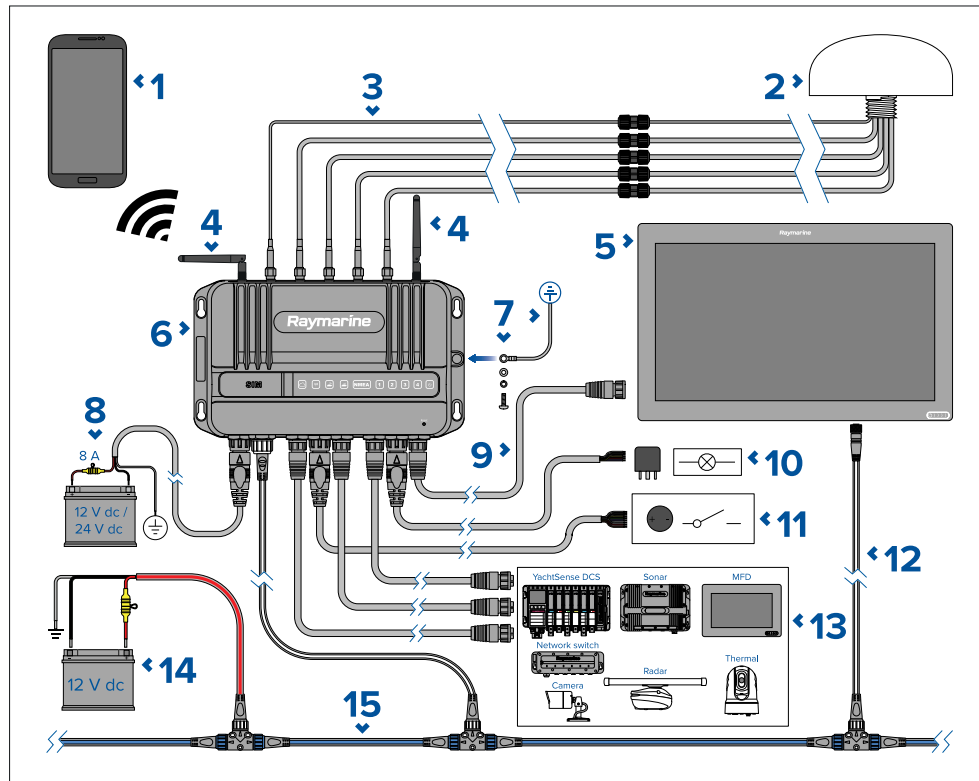

1. Mobile phone / tablet
2. 5 in 1 antenna providing GNSS/Wi-Fi/Cellular/Diversity connections (supplied)
3. Optional 5 in 1 antenna extension (A80701)
4. Boat Wi-Fi (antennas supplied)
5. Compatible MFD (e.g.: Axiom XL)
6. YachtSense™ Link Marine Cloud Router

7. Mandatory grounding connection
8. 12 V / 24 V dc router power supply
9. RayNet connection to MFD (direct or via Raymarine network switch)
10. Router output channel connections (rated at 200 mA; for controlling devices via standard automotive relays)
11. Router input channel connections (detect switch states and monitor voltage.)
12. DeviceNet to SeaTalkng® connection to MFD (via an adaptor cable, e.g.: A06075).
13. Other Raymarine products connected via RayNet (direct or via a Raymarine network switch)
14. 12 V dc SeaTalkng® power supply (with 5 A fuse)
15. SeaTalkng® backbone (requires its own 12 V power supply)

## Third party hardware with companion apps

To guarantee optimum wireless network performance the router does not bridge wired (RayNet) and wireless (Boat Wi-Fi) connections, and instead routes packets between the two networks.

This means that:

- Third-party hardware that uses mDNS can use a wired (RayNet) connection to the router and be discoverable by its companion app that is installed on a device connected to the router's wireless (Boat Wi-Fi) connection.
- Third-party hardware that does not use mDNS requires a wireless (Boat Wi-Fi) connection to the router for it to be discoverable by its companion app.
- Third-party hardware where the companion app supports fixed IP addressing for discovery can use wired (RayNet) connection to the router.

## 2.3 Parts supplied

The following parts are supplied in the box.

Unpack your product carefully to prevent damage or loss of parts. Check the box contents against the list below. Retain the packaging and documentation for future reference.

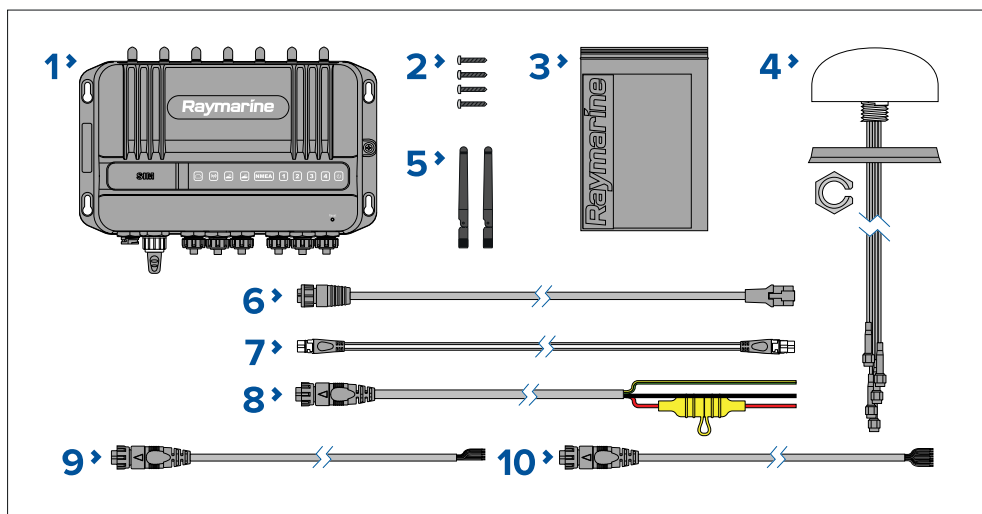

1. YachtSense™ Link Marine Cloud Router (supplied with grounding point fixings and protective caps fitted).
2. 4 x mounting fixings (PA 4 x 25 mm self tapping screws).
3. Documentation pack
4. 5-in-1 antenna (GNSS, Cellular, Diversity, DOCK WLAN) with 5 m (16.4 ft) cables and M20 nut and mounting gasket.
5. 2 x Dipole antenna (BOAT Wi-Fi).
6. RayNet to RJ45 cable 1 m (3.3 ft).
7. SeaTalkng® spur cable 1 m (3.3 ft).
8. Power cable with 8 A fitted fuse 1.5 m (4.9 ft).
9. Input cable (5–wire) 0.5 m (1.64 ft).
10. Output cable (8–wire) 0.5 m (1.64 ft).

# CHAPTER 3: YACHTSENSE ECOSYSTEM

## CHAPTER CONTENTS

- [3.1 YachtSense ecosystem — page 17](#)
- [3.2 On boat features — page 17](#)
- [3.3 Off boat premium features — page 19](#)
- [3.4 Raymarine app — page 19](#)
- [3.5 Removing a boat system — page 22](#)
- [3.6 Removing a router — page 22](#)
- [3.7 YachtSense Link router account transfer / ownership transfer — page 23](#)



## 3.1 YachtSense ecosystem

YachtSense™ is Raymarine's digital monitoring and control solution. The YachtSense™ ecosystem enables on and off boat monitoring and control of connected vessel systems and data. On boat monitoring and control can be achieved using a Raymarine Axiom MFD or the Raymarine app installed on a mobile phone or tablet. Off boat monitoring and control can be achieved using the Raymarine app. Off boat monitoring and control requires a valid premium subscription.

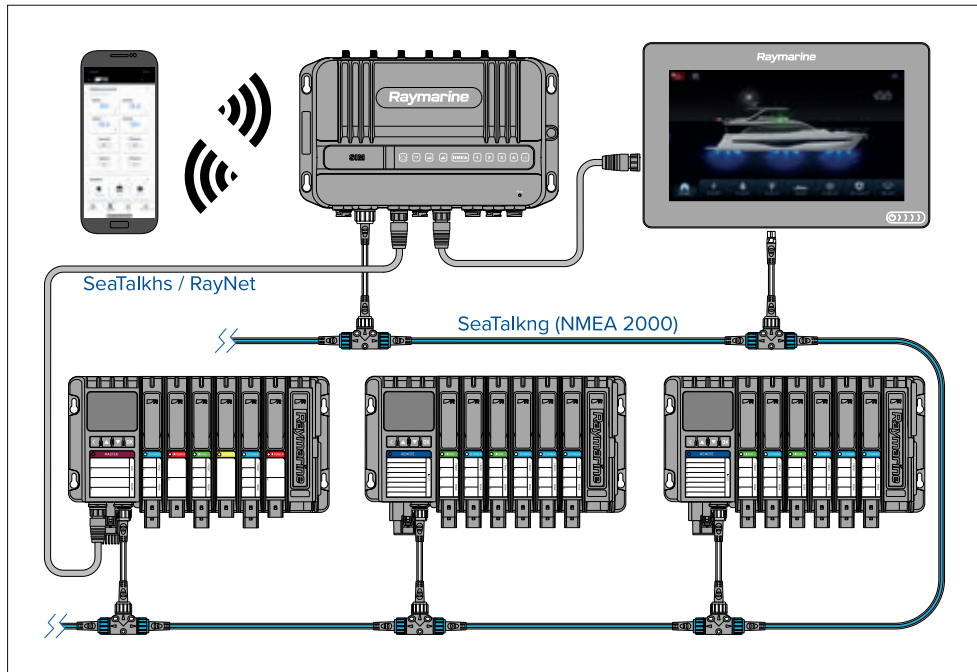

The full YachtSense™ ecosystem consist of:

- YachtSense Link router
- YachtSense Digital Control System
- Raymarine mobile app
- Premium app subscription (required for off-boat connectivity)
- Axiom MFDs

### Note:

- The YachtSense™ Link router must be connected to the same SeaTalkng backbone and as the YachtSense Digital Control System and any MFDs.
- The router also requires a RayNet connection to the YachtSense Digital Control System's master module and any MFDs.

## 3.2 On boat features

The YachtSense™ ecosystem provides on-boat features that can be used whilst onboard your vessel.

### Raymarine app connect directly to an MFD



The following features are available when using the Raymarine app on a mobile device that is connected directly to a Raymarine Axiom MFD's Wi-Fi access point:

- Stream and control the MFD.
- Download and transfer LightHouse charts to memory card or Axiom internal storage.
- Transfer files such as waypoint and settings backups, images or videos between your mobile device and MFD.
- View NMEA 2000 data.

## Raymarine app connected to YachtSense™ Link router

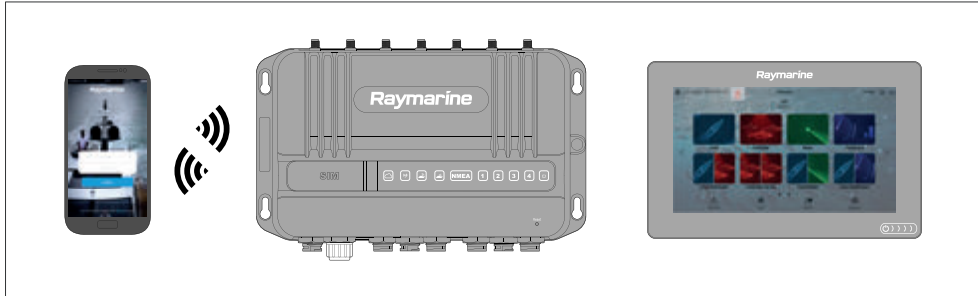

The following features are available when using the Raymarine app on a mobile device that is connected to the YachtSense™ Link router's Wi-Fi access point:

- Stream and control any MFD on the network.
- Download and transfer LightHouse charts to memory card or Axiom internal storage.
- Transfer files such as waypoint and settings backups, images or videos between your mobile device and MFD.
- View NMEA 2000 data.
- Voltage monitoring of devices connected to the router's input channels (the router's web interface can also be used to monitor input channels).
- Control of devices connected to the router's output channels (the router's web interface can also be used to control output channels).

## Raymarine app connected to YachtSense™ Link router with YachtSense™ Digital Control System

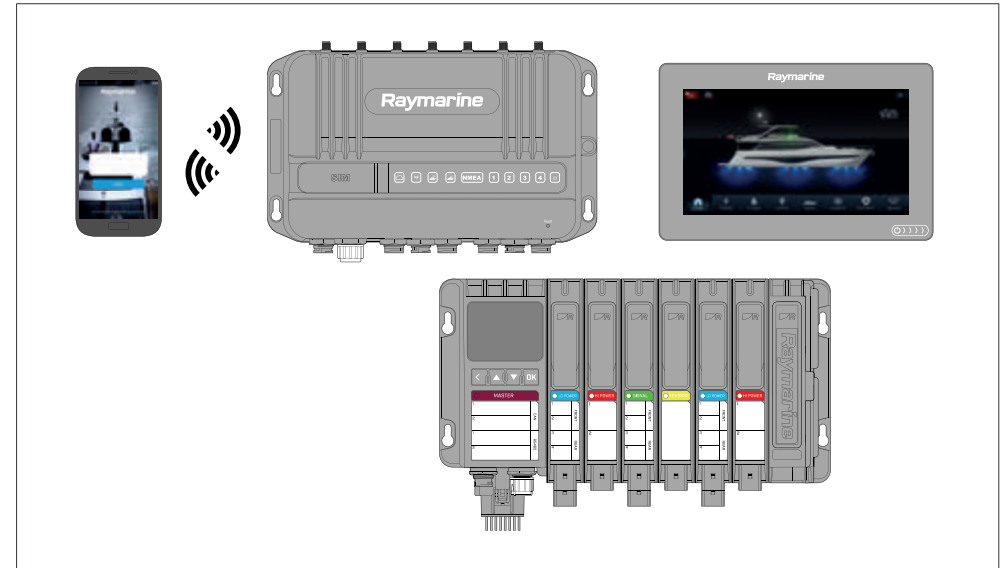

The following features are available when using the Raymarine app on a mobile device that is connected to the YachtSense™ Link router's Wi-Fi access point on systems that include a YachtSense™ Digital Control System:

- Stream and control any MFD on the network.
- Download and transfer LightHouse charts to memory card or Axiom internal storage.
- Transfer files such as waypoint and settings backups, images or videos between your mobile device and MFD.
- View NMEA 2000 data.
- Voltage monitoring of devices connected to the router's input channels (the router's web interface can also be used to monitor input channels).
- Control of devices connected to the router's output channels (the router's web interface can also be used to control output channels).
- Monitoring and control of vessel systems and devices connected to the YachtSense™ Digital Control System input and output channels (input and output channels can also be monitored and controlled using a Raymarine MFD or directly from the master or remote module).

**Note:**

YachtSense™ Digital Control System requires specific configuration for the Raymarine app.

### 3.3 Off boat premium features

The YachtSense™ ecosystem provides off-boat features that can be used whilst away from your vessel.

**Note:**

- Off-boat features require a YachtSense™ Link router and a valid premium subscription to the Raymarine app.
- YachtSense™ Digital Control System requires specific configuration for the Raymarine app.

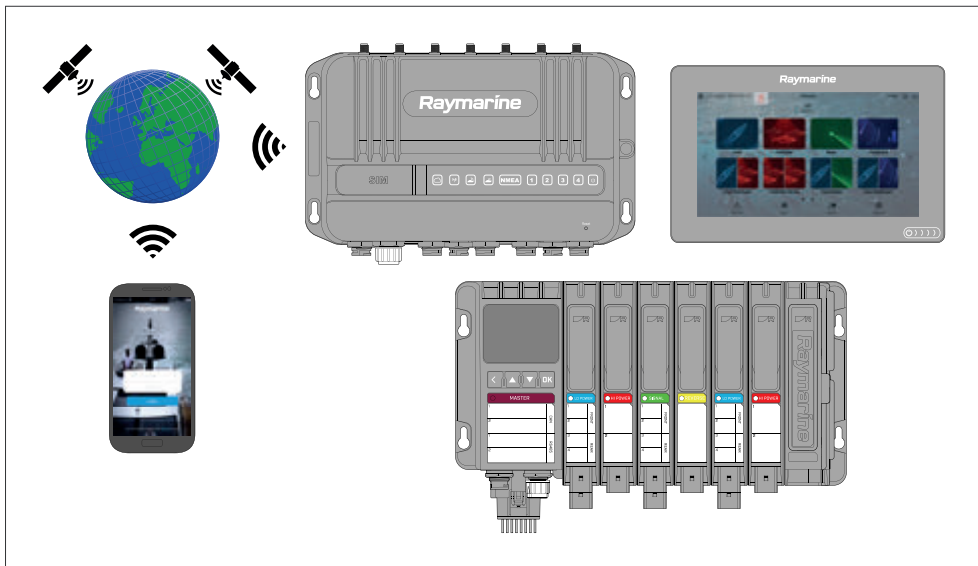

Whilst off-boat you can:

- Monitor your vessel's location using the app's geofence.
- View NMEA 2000 data.
- Voltage monitoring of devices connected to the router's input channels.
- Control of devices connected to the router's output channels.

- Monitoring and control of vessel systems and devices connected to the YachtSense™ Digital Control System input and output channels.

### 3.4 Raymarine app

The Raymarine app is available for Android and iOS devices and can be installed from the relevant app store.

You will need to create a Raymarine account to log in to the app.

#### How to connect guide

If the app is not currently connected to a boat system the **How to connect** option is available to guide you through setting up a boat system and connecting to your chartplotter or YachtSense Link router.

#### Connect to a chartplotter directly

You must be connected directly to the chartplotter's Wi-Fi connection.

If your chartplotter does not have an internet connection then you must log in to the Raymarine app first before switching network.

If your chartplotter does not have a connection to the internet, when you connect to it, your mobile device may automatically switch back to its previous network. If you try to connect again a notification should be displayed. Select **Connect** or **Connect anyway**.

When you are connected to a chartplotter you can:

- [Start display mirroring](#)
- [View data](#)
- [Transfer files](#)
- [Transfer LightHouse charts](#)

When connecting directly to a chartplotter it must be configured to allow Wi-Fi sharing: **Homescreen > Settings > This display > Wi-Fi Sharing**.

#### Display mirroring (view and control)

You can view and control your chartplotter from the Raymarine app.

Chartplotters will be available under **Display mirroring** in the **Control** tab when they are connected to the same Wi-Fi network as your mobile device. Select a chartplotter to initiate display mirroring.

## Transferring LightHouse charts

The Raymarine app can be used to redeem LightHouse chart vouchers and to download and transfer the charts directly to your chartplotter.

### Note:

To download LightHouse charts to a memory card you must purchase a pre-formatted LightHouse charts MicroSD card (R70795 or R70838 and insert it into your MFD before starting the transfer process.

1. Select the **Management** icon located at the bottom of the screen.
2. Select **Charts**.  
If you have already purchased charts then the **My charts** menu will show your available charts. Otherwise the **Chart catalog** is displayed where you can search for charts and redeem voucher codes.
3. Select the chart from the **My charts** menu that you want to download.
4. Follow the onscreen instructions to download your charts.

*You will be able to group chart regions, Add Streets & POI and Aerial photos areas and select a storage location during the download process.*

### Note:

Chart downloads have large file sizes and so may take some time to download and transfer.

## Chartplotter file transfer

File transfer between chartplotter and your mobile device is available using the **The Chartplotter file transfer** option in the **Management** tab.

The first time file transfer is used you will have to confirm access from the chartplotter.

You can select a chartplotter and then browse internal and external storage for either a file to upload to your mobile device or a location to upload a file from your mobile device.

Selecting a file from your chartplotter will provide related options where you can:

- View the file
- Copy the file.
- Share the file.

You can also upload a file from your mobile device to your chartplotter by selecting **Upload a file here**.

### Note:

You cannot delete files that are on your chartplotter from the Raymarine app.

## Connect to your YachtSense Link router

After setting up your YachtSense Link router and configuring its wireless networks (Wi-Fi and / or cellular (mobile) connections) you can use the Raymarine app to create a boat system and link your router to your Raymarine account. Linking allows off boat monitoring and control of compatible systems connected to your router.

### Note:

- You cannot link a router that is already linked to a different account.
- If your mobile device is already connected to a boat system it must be disconnected before another boat system can be added.
- The premium subscription features can only be used on 2 boat systems at a time.

The linking process includes:

1. Connecting your mobile device to your **YachtSense Link** router's Wi-Fi connection.
2. Creating a boat system by entering your boat's name.
3. Scanning the router's QR code to connect the router to your account. The QR code can be found on the label on the side of your router or on the Info page of the router's web interface.

When connected to the router you can:

- [Create geofences](#)
- [View data](#)
- [Control digital switching input and output channels](#)
- [Start display mirroring](#)
- [Transfer files](#)
- [Transfer LightHouse charts](#)

## Geofencing

A Geofence is a security feature that alerts you if your boat leaves or enters a chosen area.

When a geofence alert is triggered a notification will be sent to the cellular telephone number specified in the Boat alerts settings.

Geofencing is available with a premium Raymarine app subscription.

### Geofence

When your boat system includes a YachtSense Link router you can set up geofences.

1. Select **+ Add new geofence** from the Geofence tab.
2. Select **Radius**.

*A geofence circle is placed over your vessel.*

3. Increase or decrease the geofence radius by selecting the circle and dragging towards or away from you vessel's location.

*Alternatively you can use the **+** (plus) and **-** (minus) buttons to fine tune the circle radius.*

4. Select the Name field to customize the geofence name.
5. Enable the Boat leaves location and / or Boat enters location toggle switches as appropriate for your needs.
6. If desired, change the color of the geofence by selecting the colored circle in the Color area.
7. Select **Create** from the top of the screen.

Multiple geofences can be created. The geofence circle radius can be adjusted or can be disarmed by selecting the relevant geofence details located at the bottom of the screen.

### Temporary mooring

You can also create a temporary mooring geofences for short stay stops.

Temporary mooring geofences are only triggered when your vessel exits the geofence circle and are automatically deleted when it is disarmed.

You can only create 1 temporary mooring geofence. Creating a second will replace the first geofence.

## Data view and channel control

Depending on your systems configuration you will also be able to view live data and control certain channels using the app.

- A data page can be created to view compatible data that is available on your chartplotter's or Router's network.
- When connected to a boat system that includes a YachtSense Link router you can view the status of the input channels and switch the output channels on and off from the Control tab. If the channel has been disabled in the router's web interface then the channel will not be shown in the app.
- When your boat system includes both a YachtSense Link router and a Yachtsense Digital Control System the input and output channels status and controls can be made available from the Control tab.
- When you have an active premium Raymarine app subscription and your boat system includes both a YachtSense Link router and a Yachtsense Digital Control System the input and output channels status and controls can be accessed remotely when you are away from your boat.

### Note:

For Yachtsense Digital Control System controls to be available on the Raymarine app your for Yachtsense Digital Control System configuration must include the necessary app page layouts. If required, please contact your Yachtsense Digital Control System installer to organise an updated configuration to be created.

### Viewing NMEA 2000 (SeaTalkng) data

To create a data page for NMEA 2000 / SeaTalkng data follow the steps below.

1. Select **Add data** from the Data tab..
2. Select a data category and then select the relevant data item..
3. To add more data items select the **+** (plus) icon and repeat steps 2 and 3.
4. Select **Done** when finished..

To delete a data item press and hold and then drag it to the trash bin icon at the bottom of the screen.

You can add or change data items at anytime by selecting the **Edit** icon from the top of the data page.

## User access management

You can log out / in to your account, edit your user account details or update your premium plan subscription by selecting the profile icon on the right side of the side menu.

### Guest accounts

If you are on a friends boat or are borrowing / chartering a boat that includes a Raymarine chartplotter or YachtSense Link router you can link to the system as a guest.

#### Note:

Guests will not be able to create geofences, upload files or transfer LightHouse charts. Guests will also not have access to Yachtsense Link and YachtSense Digital Control System input and output channels.

## Boat alerts

Alerts raised by your system can be viewed in the app by selecting Boat alerts from the side menu.

You can also enter a cellular telephone number to automatically receive boat alerts on your mobile device remotely.

The cellular telephone number can be entered by selecting the settings icon from the boat alerts menu.

## Boat systems

You can create / connect up to 10 boat systems to the Raymarine app. With an active premium Raymarine app subscription up to 2 boat systems can be configured to receive premium features.

## 3.5 Removing a boat system

A boat system can be removed from the Raymarine app following the steps below:

1. Select the menu icon located on the left of the screen to open the side menu.
2. Select and hold on the boat system of the boat you want to remove.

*If you have more than one boat set up, you will first need to select the relevant boat system from the dropdown list.*

3. Select **Delete** and then confirm the deletion.
4. Select **OK**.
5. You must also unsync the MFD from the Raymarine app by accessing the **My data** menu on your MFD and selecting **Mobile sync** and **Cancel Raymarine app sync**.

The boat system and all of its devices are now removed from your app. If the deleted boat system included a YachtSense link router then the router will also be removed (offboarded) from your account and can now be linked (onboarded) again to the same account, or to a different account.

#### Note:

The router should be power cycled before attempting to link (onboard) it again.

## 3.6 Removing a router

You can remove a YachtSense Link router from a boat system in the Raymarine app by following the steps below.

1. Select the menu icon located on the left of the screen to open the side menu.
2. If you have more than one boat system, select the relevant boat system that the router is connected to.
3. Select the **YachtSense Link** router.
4. Select **Remove** and then confirm the removal
5. You must also unsync the MFD from the Raymarine app by accessing the **My data** menu on your MFD and selecting **Mobile sync** and **Cancel Raymarine app sync**.

The router is now removed from the boat system and removed (offboarded) from your account. The router can now be linked (onboarded) again to the same account, or to a different account.

#### Note:

The router should be power cycled before attempting to link (onboard) it again.

## 3.7 YachtSense Link router account transfer / ownership transfer

Yachtsense Link routers can only be linked to one account at a time.

To link the router to a different account it must first be removed from the existing account (“Offboarding”). For instructions refer to:

[p.22 – Removing a router](#)

### **Attempts to link to a router that is already linked to an account will fail.**

If you receive a message when trying to link to your router that states it is already assigned to another account, you will need to contact the previous owner and ask them to remove the router from their account.

If you cannot contact the previous owner, Raymarine technical support may be able to contact them on your behalf.

In most cases if the previous owner cannot be reached or is unwilling to remove the router from their account, it will NOT be possible for you to link your router.

If you purchased the router new, via either a third party reseller or as a refurbished unit, and you receive a message that your router is already assigned to an account, you should return it to the seller for a refund or exchange and let them know that it is already linked to another account.

# CHAPTER 4: INSTALLATION

## CHAPTER CONTENTS

- 4.1 Tools required — page 25
- 4.2 Selecting a location — page 25
- 4.3 YachtSense™ Link product dimensions — page 28
- 4.4 5-in-1 antenna dimensions — page 29
- 4.5 Inserting SIM cards — page 29
- 4.6 Mounting the YachtSense™ Link — page 31
- 4.7 Mounting the 5-in-1 antenna — page 32



## 4.1 Tools required

The following tools are required for installation.

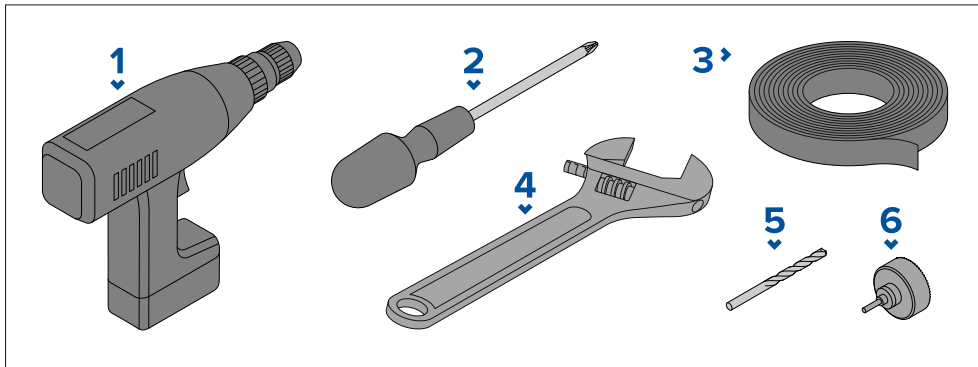

1. Power drill
2. Pozi-drive screw driver
3. Masking / adhesive tape
4. Adjustable wrench / 30 mm wrench (Required for 5-in-1 antenna installation.)
5. Drill bit (suitable for pilot holes)
6. 23 mm (0.91 in) hole cutter (Required for 5-in-1 antenna installation.)

## 4.2 Selecting a location

### Warnings and cautions

**Important:** Before proceeding, ensure that you have read and understood the warnings and cautions provided in the [p.9 – Important information](#) section of this document.



#### Warning: Potential ignition source

This product is NOT approved for use in hazardous/flammable atmospheres. Do NOT install in a hazardous/flammable atmosphere (such as in an engine room or near fuel tanks).

## YachtSense™ Link location requirements

The installation location must take into account the following requirements: This product is not suitable for installation in above decks locations, unless installed in a suitable protective enclosure. In this scenario, it's important to avoid using enclosure materials that will have a significant impact on the wireless signals, such as conductive materials like steel or carbon fibre, for example.

### Wireless location requirements for optimum performance

All wireless devices in your system must be located in such a way that they can reliably receive and/or transmit wireless signals.

A number of factors can influence wireless performance. For example, physical obstacles and certain vessel structures and materials can all negatively impact wireless performance. Therefore, **it's important to check a product's wireless performance at the desired installation location before drilling any mounting holes.**

### Vessel construction and materials

Wherever possible, mount products on surfaces constructed from GRP (e.g. fiberglass resin, or foam), or on dry wooden bulkheads.

**Conductive materials in the signal path can have a significant impact on wireless signal performance.** Reflective surfaces such as metal surfaces, some types of glass and even mirrors can drastically affect performance or even block the wireless signal. Installation locations that are in close proximity to these materials should be avoided. **Do NOT mount wireless products directly to conductive materials.** This includes any mounting surface or enclosure/pod.

Examples of conductive materials include, but are not limited to:

- carbon fibre, kevlar, or aramid (including sails made from these materials)
- aluminium
- steel

In installations with conductive materials, mount the wireless product using an accessory pole mount or deck mounting kit. A clearance of at least 10 cm (3.9 in) is required to minimize the ground effect from conductive materials. This applies to transmitters as well as displays. If moving the product fixes the problem, consider cutting an antenna clearance hole behind the unit (once the product position and mounting have been finalized).

Wireless performance can also be degraded in locations where the wireless signal passes through a bulkhead containing power cables.

**Note:**

Crew members (especially when wet) can also be obstructive to wireless signals, if their bodies pass through the signal area between wireless sensor and any associated displays.

**Checking and optimizing signal strength**

It may be necessary to experiment with the location of your wireless products to achieve optimal wireless performance and a clear signal path.

The distance between wireless products should always be kept to a minimum. Do not exceed the maximum stated range of your wireless product (maximum range will vary for each device).

Wireless performance degrades over distance, so products farther away will receive less network bandwidth. Products installed close to their maximum wireless range may experience slow connection speeds, signal dropouts, or not being able to connect at all.

For best results, the wireless product should have a clear, direct line-of-sight to the product it will be connected to. Any physical obstructions can degrade or even block the wireless signal.

Some wireless products feature a signal strength indicator to assist in the process of determining the location with the best wireless performance. Choose the location with the highest and most consistently strong direct signal reading, during a 5 minute monitoring period. Try alternative locations for the transmitter to maximise the signal strength to the displays; e.g. try locations below a hatch or skylight or near to a window. A small change in product position can result in a significant change in the signal strength.

**Note:**

Some wireless products (e.g. a Hull Transmitter) will not transmit data unless a transducer is connected. Also consider that an NMEA or SeaTalkng product (e.g. an interface) will not transmit data unless an appropriate data source is connected.

**Interference and other equipment**

Interference from other people's wireless devices can cause interference with your products. You can use a third-party wireless analyzer tool / smartphone app to assess the best wireless channel to use (e.g. a channel not in use or one used by the least number of devices).

Wireless products should be installed at least 1 m (3 ft) away from:

- Other wireless-enabled products
- Transmitting products that send wireless signals in the same frequency range
- Other electrical, electronic or electromagnetic equipment that may generate interference.

**Software updates**

It's also important to ensure all your wireless products are running the latest software versions, as improvements are made over time to wireless performance.

**Mounting surface requirements**

When selecting a mounting surface ensure:

- the product will be adequately supported on a secure, flat surface. Do NOT mount units or cut holes in places which may damage the structure of the vessel.
- sufficient space is available around the product.
- there is nothing behind the mounting surface that may be damaged when drilling.

**Cable routing requirements**

Ensure you have identified the route that all required cables will take and that sufficient space is available to allow connection of cables:

- Unless otherwise stated, a minimum cable bend radius of 100 mm (3.94 in) is required.
- Where necessary, cable supports should be used to prevent stress on connectors.

**Electrical interference**

Select a location that is far enough away from equipment that may cause interference, such as motors, generators and radio transmitters/receivers.

**Power supply**

Select a location that is as close as possible to the vessel's DC power supply. This will help to keep cable runs to a minimum.

## RF interference

Certain third-party external electrical equipment can cause Radio Frequency (RF) interference with GNSS (GPS), AIS or VHF devices, if the external equipment is not adequately insulated and emits excessive levels of electromagnetic interference (EMI).

Some common examples of such external equipment include LED lighting (e.g.: navigation lights, searchlights and floodlights, interior and exterior lights) and terrestrial TV tuners.

To minimize interference from such equipment:

- Keep it as far away from GNSS (GPS), AIS or VHF products and their antennas as possible.
- Ensure that any power cables for external equipment are not entangled with the power or data cables for these devices.
- Consider fitting one or more high frequency suppression ferrites to the EMI-emitting device. The ferrite(s) should be rated to be effective in the range 100 MHz to 2.5 GHz, and should be fitted to the power cable and any other cables exiting the EMI-emitting device, as close as possible to the position where the cable exits the device.

## Compass safe distance

When choosing a suitable location for your product you should aim to maintain the maximum possible distance between the product and any installed compass. This distance should be at least 1 m (3 ft) in all directions. For smaller vessels it may not be possible to achieve this distance. In this situation ensure that the compass is not affected by the product when it is powered on.

## EMC installation guidelines

Raymarine equipment and accessories conform to the appropriate Electromagnetic Compatibility (EMC) regulations, to minimize electromagnetic interference between equipment and minimize the effect such interference could have on the performance of your system.

Correct installation is required to ensure that EMC performance is not compromised.

### Note:

In areas of extreme EMC interference, some slight interference may be noticed on the product. Where this occurs the product and the source of the interference should be separated by a greater distance.

For **optimum** EMC performance we recommend that wherever possible:

- Raymarine equipment and cables connected to it are:
  - At least 1 m (3.3 ft) from any equipment transmitting or cables carrying radio signals e.g. VHF radios, cables and antennas. In the case of SSB radios, the distance should be increased to 2 m (6.6 ft).
  - More than 2 m (6.6 ft) from the path of a radar beam. A radar beam can normally be assumed to spread 20 degrees above and below the radiating element.
- The product is supplied from a separate battery from that used for engine start. This is important to prevent erratic behavior and data loss which can occur if the engine start does not have a separate battery.
- Raymarine specified cables are used.
- Cables are not cut or extended, unless doing so is detailed in the installation manual.

### Note:

**Where constraints on the installation prevent any of the above recommendations**, always ensure the maximum possible separation between different items of electrical equipment, to provide the best conditions for EMC performance throughout the installation.

## Suppression ferrites

- Raymarine cables may be pre-fitted or supplied with suppression ferrites. These are important for correct EMC performance. If ferrites are supplied separately to the cables (i.e. not pre-fitted), you must fit the supplied ferrites, using the supplied instructions.
- If a ferrite has to be removed for any purpose (e.g. installation or maintenance), it must be replaced in the original position before the product is used.
- Use only ferrites of the correct type, supplied by Raymarine or its authorized dealers.

- Where an installation requires multiple ferrites to be added to a cable, additional cable clips should be used to prevent stress on the connectors due to the extra weight of the cable.

## Connections to other equipment

Requirement for ferrites on non-Raymarine cables.

If your product is to be connected to other equipment using a cable not supplied by Raymarine, a suppression ferrite **MUST** always be attached to the end of the cable nearest to the Raymarine product.

## 5-in-1 antenna location requirements

The supplied 5-in-1 antenna must be mounted in a location that provides a clear unobstructed view of the sky.

Ensure that the selected mounting location is:

- Open and clear of any obstructions (such as masts, search lights, or other structures) that could block line-of-sight to the sky.
- As low as possible, to keep the antenna as stable as possible. The more stable the antenna, the more effectively it will track satellites and provide stable data.
- As far as possible (at least 1 m (3 ft)) from other antennas and electronic equipment.

Do NOT mount the antenna:

- In any area where it could be stepped on or tripped over.
- Up a mast. This will cause the antenna to swing and give significant errors in position data.
- In the direct path of a Radar beam.

## 4.3 YachtSense™ Link product dimensions

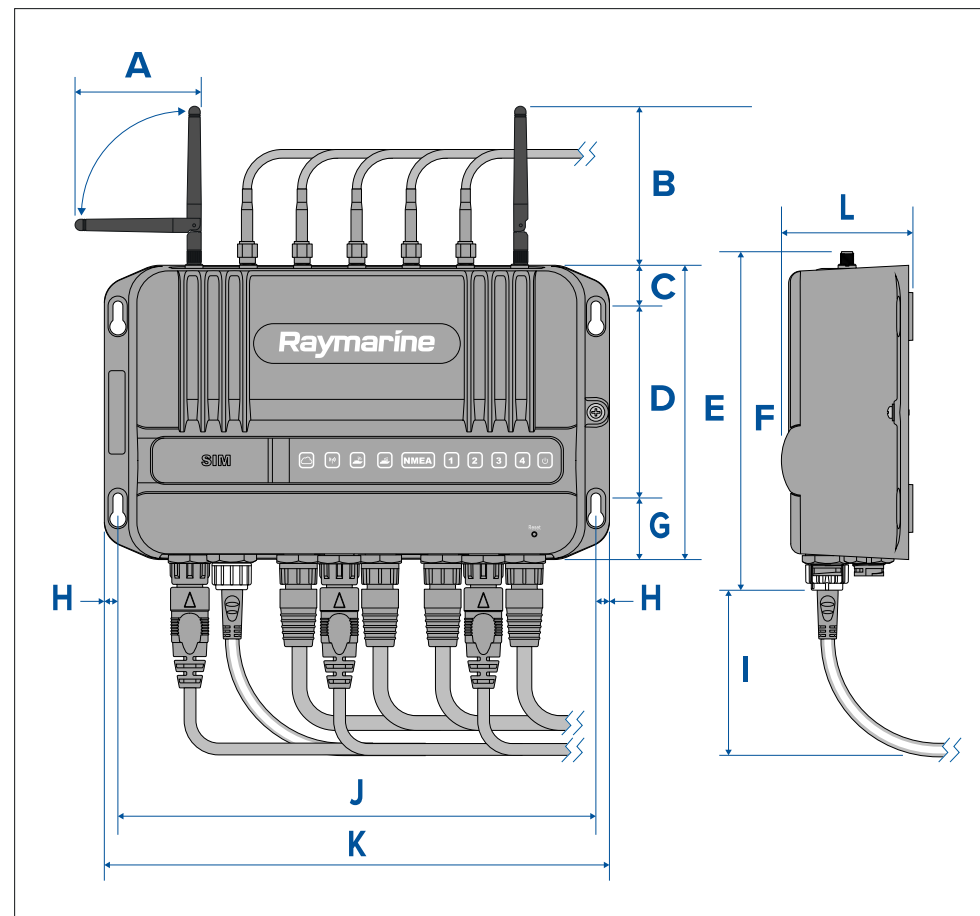

- **A** = 87.80 mm (3.46 in)
- **B** = 108.40 mm (4.27 in)
- **C** = 19.50 mm (0.78 in)
- **D** = 108.20 mm (4.26 in)
- **E** = 141.00 mm (5.55 in)
- **F** = 162.20 mm (6.39 in)
- **G** = 29.50 mm (1.16 in)
- **H** = 6.50 mm (0.26 in)
- **I** = 80.00 mm (3.15 in)

- **J** = 229.00 mm (9.02 in)
- **K** = 242.00 mm (9.53 in)
- **L** = 63.00 mm (2.48 in)

## 4.4 5-in-1 antenna dimensions

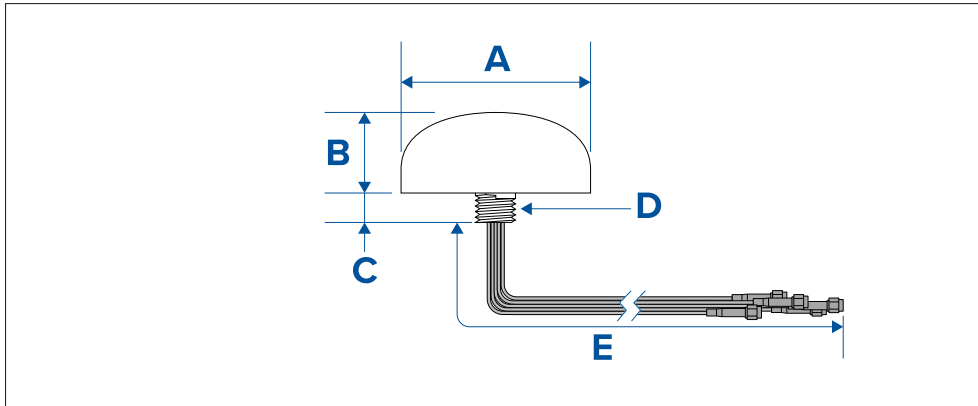

- **A** = Ø 102.90 mm (4.05 in)
- **B** = 43.50 mm (1.71 in)
- **C** = 16.00 mm (0.63 in)
- **D** = 7/8"-9 UNC thread
- **E** = 5 m (16.4 ft)

## 4.5 Inserting SIM cards

YachtSense™ Link has dual SIM card slots which accept Micro SIM cards (Nano SIMs can be used with a Nano to Micro SIM adaptor).

### Important:

- A SIM card is not supplied with the YachtSense™ Link and will need to be purchased separately.
- If only using a single SIM card it should be inserted into SIM slot 1.
- Once SIM cards are inserted the router must be configured to allow use of mobile data. Refer to: [p.53 — Mobile data & SIM management page](#)

1. Open the SIM card door.

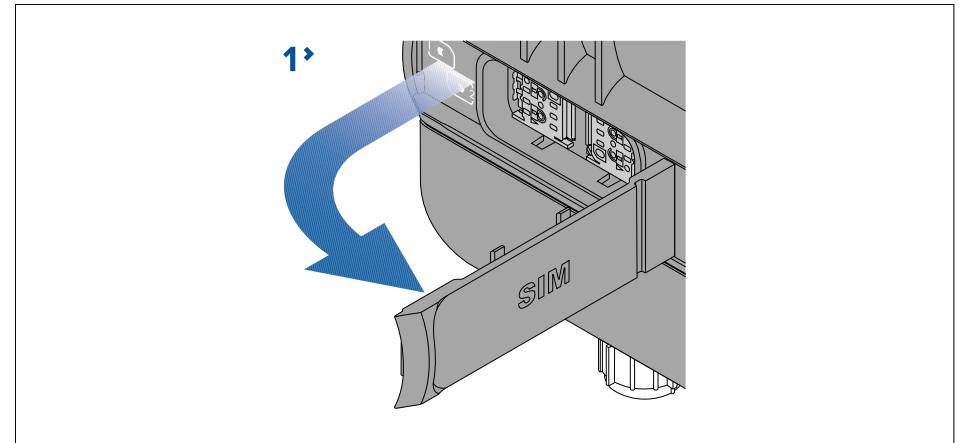

2. Slide the SIM card holder(s) into the unlocked position.

*SIM 1 slides to the left and SIM 2 slides to the right.*

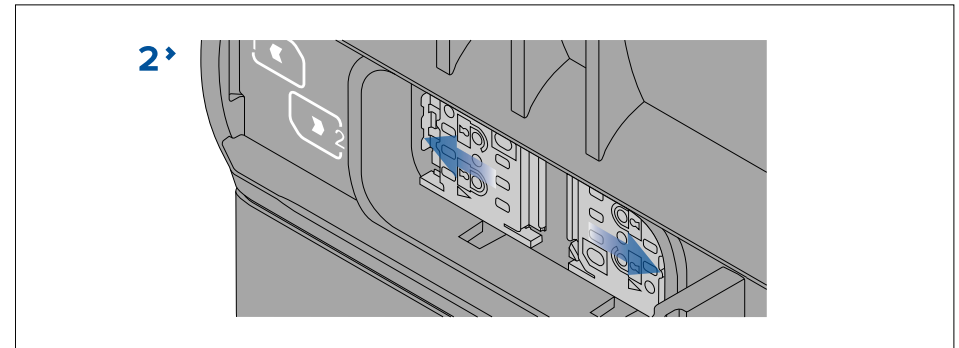

3. Open the SIM card holder(s).

*SIM 1 is hinged on the left and SIM 2 is hinged on the right.*

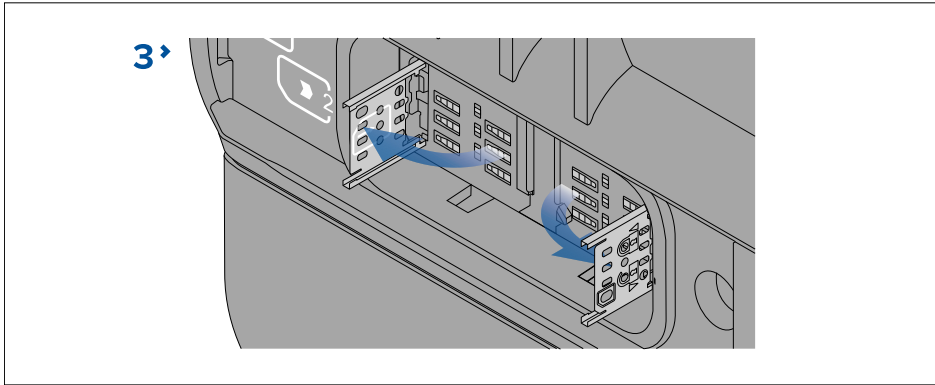

4. Ensuring correct orientation, insert your Micro SIM card(s) into the holders.

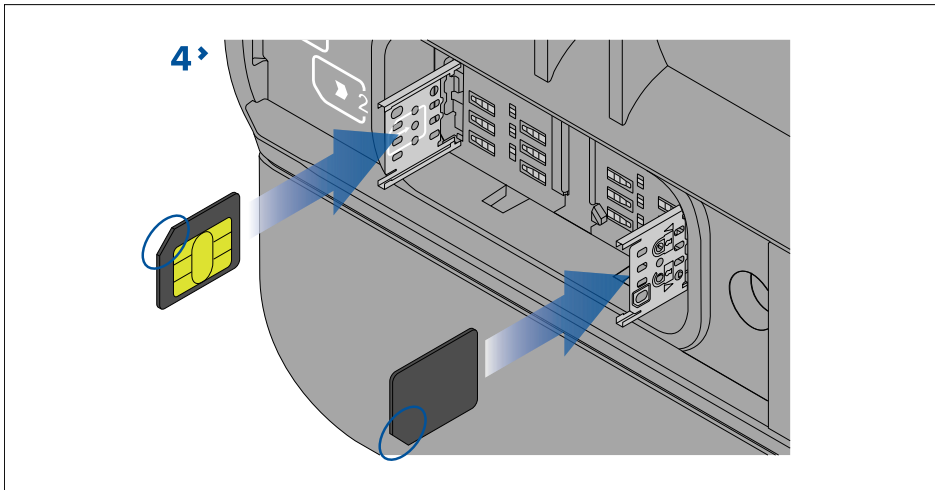

5. Close the SIM card holder(s).

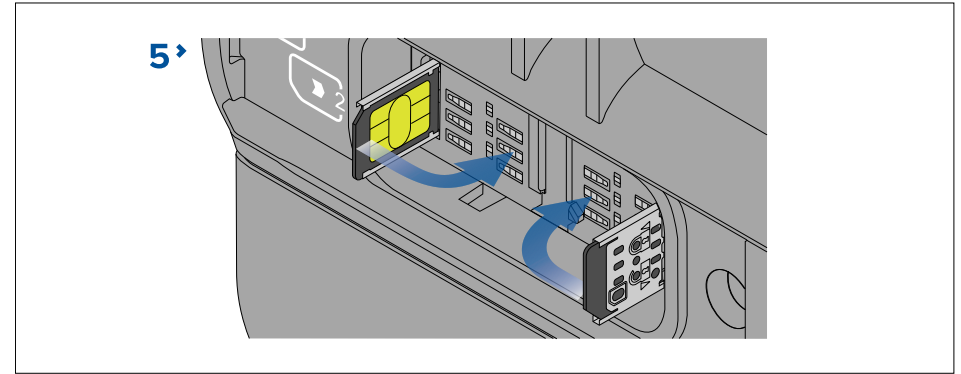

6. Slide the SIM card holder(s) into the locked position.

*SIM 1 slides to the right and SIM 2 slides to the left.*

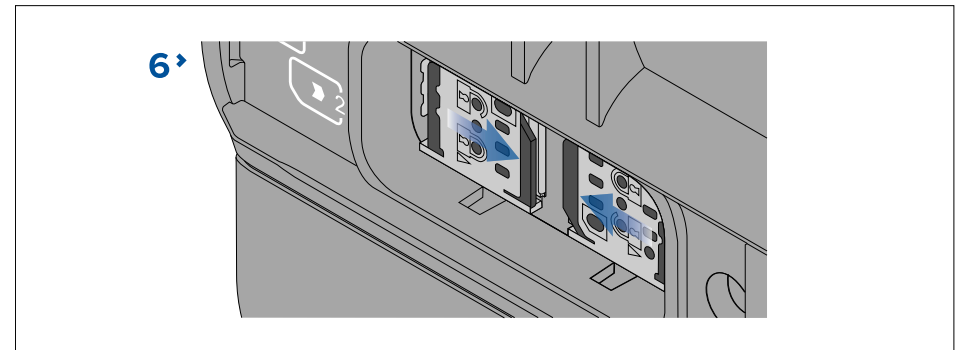

7. Close the SIM card door, ensuring that it is correctly seated all the way around the edge.

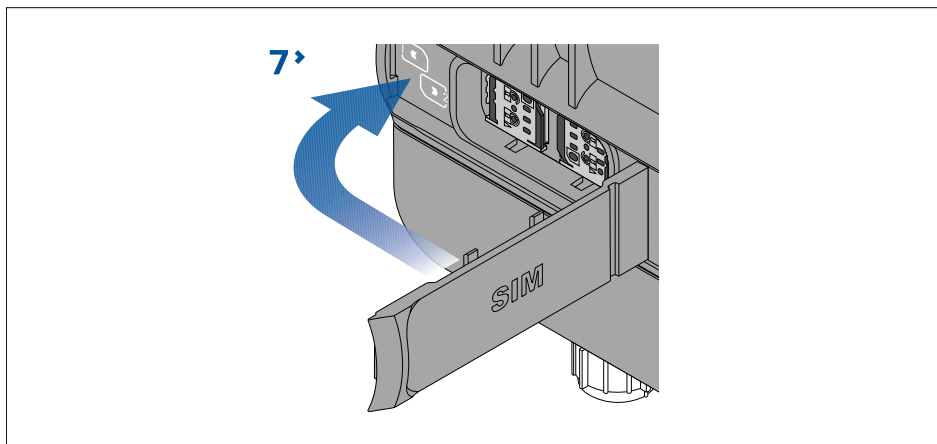

## 4.6 Mounting the YachtSense™ Link

Follow the instructions below to mount the YachtSense™ Link.

Before mounting the product ensure that you have:

- selected a suitable location, based on the location requirements found in this document.
- identified the relevant cable connections and the route that the cables will take.

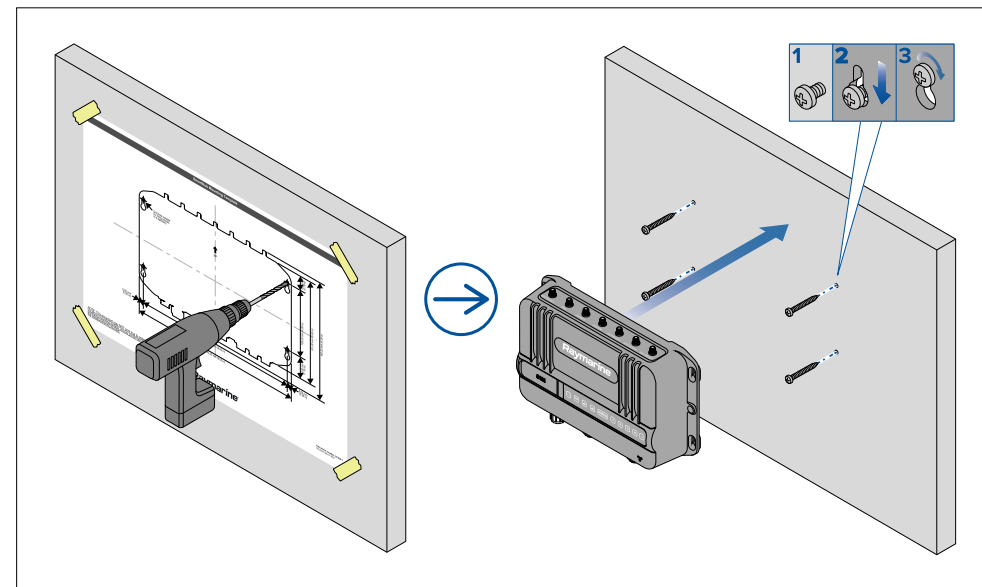

1. Fix the supplied mounting template to the chosen location using masking or self-adhesive tape.
2. Drill 4 holes as indicated on the template to accept the fixings.
3. Remove the mounting template.
4. Screw the fixings approximately half way into the holes in the mounting surface.
5. Place the unit over the fixings screws and push down to engage the keyhole slots.
6. Fully tighten the screws.

## 4.7 Mounting the 5-in-1 antenna

The supplied 5-in-1 antenna must be installed in a location which has a clear line of sight to the sky and where it will be away from structure and devices that could cause interference.

### Important:

A thread extender kit is available that enables the antenna to be mounted to a thicker mounting surface. Refer to the instructions supplied in the kit (document number 82425) for instructions on mounting the antenna, as the thread extender kit requires a bigger mounting hole size and wrench for tightening the nut.

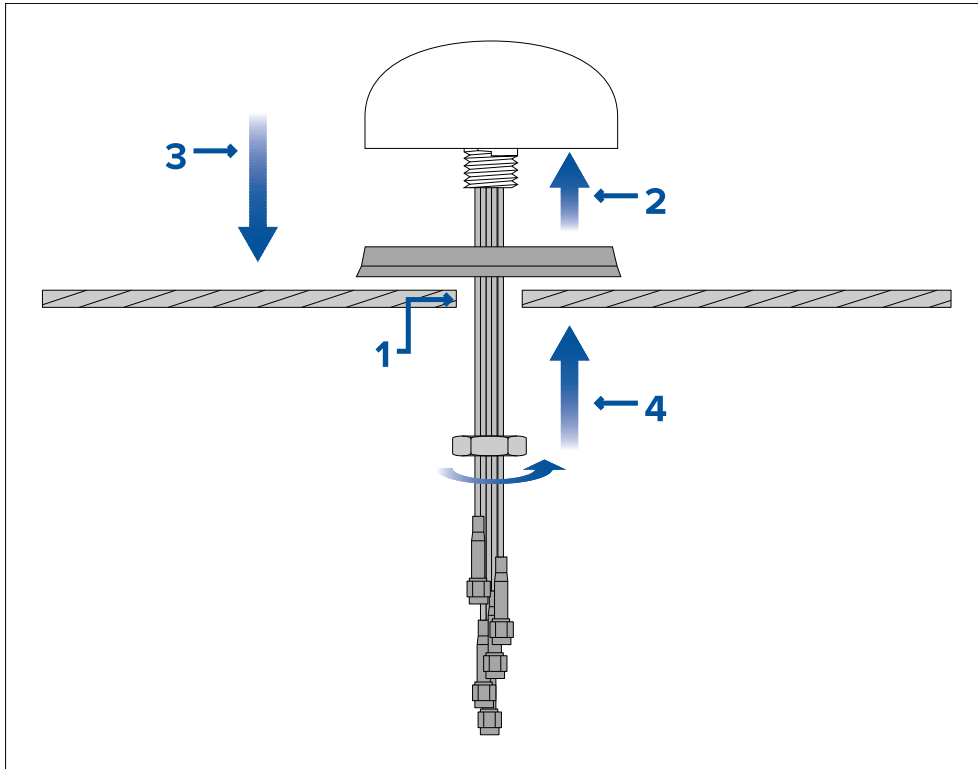

1. Drill a 23 mm (0.91 in) hole at the center of the desired mounting location to accept the antenna's thread and cables.
2. Feed the cables through the gasket and place on the underside of the antenna.

3. Feed the cables and thread through the hole in the mounting surface so that the gasket and antenna sit flush on the mounting surface.
4. Feed the cables through the split in the nut and secure the antenna by tightening the nut on the exposed thread.

*Tighten the split nut using a large adjustable wrench or a 30 mm wrench. The tightening torque should not exceed 1.47 N·m (1.08 lbf·ft).*



# CHAPTER 5: CONNECTIONS

## CHAPTER CONTENTS

- 5.1 General cabling guidance — page 34
- 5.2 YachtSense Link system diagram — page 34
- 5.3 Connections overview — page 35
- 5.4 MFD connections — page 35
- 5.5 YachtSense ecosystem — page 36
- 5.6 Power connection — page 36
- 5.7 Grounding connection — page 39
- 5.8 5-in-1 antenna connections — page 40
- 5.9 Boat Wi-Fi antenna connections — page 41
- 5.10 RayNet connections — page 42
- 5.11 Third party hardware with companion apps — page 42
- 5.12 SeaTalkng connection — page 42
- 5.13 Input and output channels — page 43
- 5.14 Input channel connection wiring — page 43
- 5.15 Output channel wiring — page 44

## 5.1 General cabling guidance

### Cable types and length

It is important to use cables of the appropriate type and length.

- Unless otherwise stated only use cables supplied by Raymarine.
- Where it is necessary to use non-Raymarine cables, ensure that they are of correct quality and gauge for their intended purpose. (e.g.: longer power cable runs may require larger wire gauges to minimize voltage drop along the run).

### Strain relief

Use adequate strain relief for cabling to ensure that connectors are protected from strain and will not pull out under extreme sea conditions.

### Cable shielding

Ensure that cable shielding is not damaged during installation and that all cables are properly shielded.



#### Warning: Positive ground systems

Do not connect this unit to a system which has positive grounding.

### Connecting cables

Follow the steps below to connect the cable(s) to your product.

1. Ensure that the vessel's power supply is switched off.
2. Ensure that the device being connected has been installed in accordance with the installation instructions supplied with that device.
3. Ensuring correct orientation, push cable connectors fully onto the corresponding connectors.
4. Engage any locking mechanism to ensure a secure connection (e.g.: turn locking collars clockwise until tight, or in the locked position).
5. Ensure any bare ended wire connections are suitably insulated to prevent shorting and corrosion due to water ingress.

## 5.2 YachtSense Link system diagram

The following diagram provides an overview of a typical system, including the available connections and the types of devices that can be connected to your router.

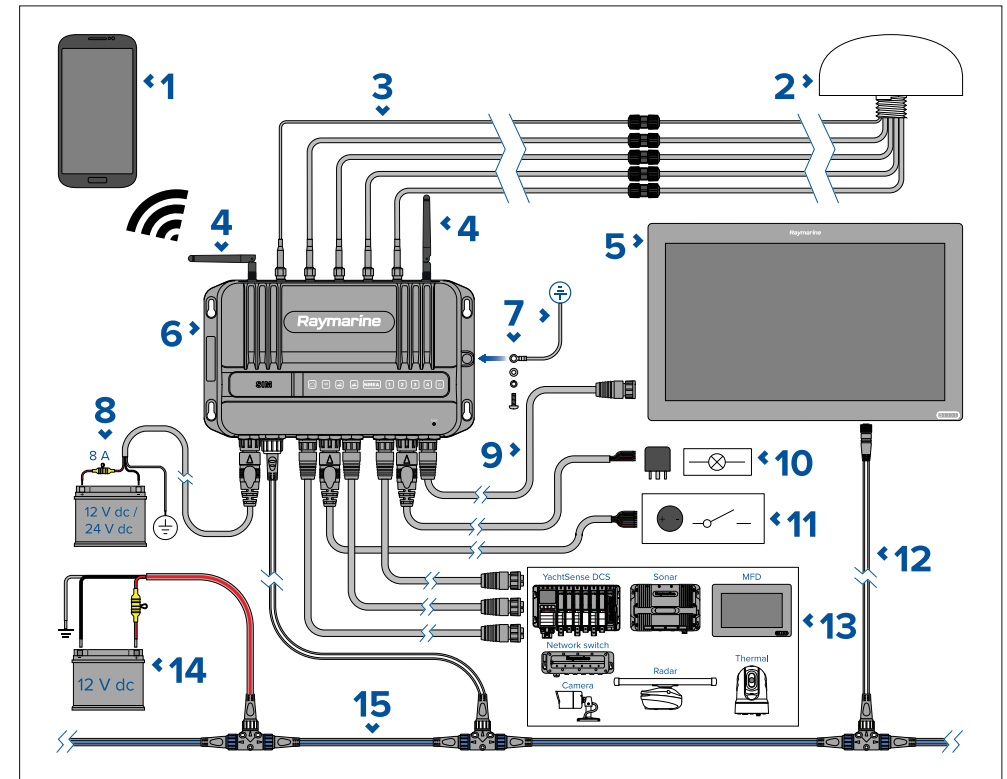

1. Mobile phone / tablet
2. 5 in 1 antenna providing GNSS/Wi-Fi/Cellular/Diversity connections (supplied)
3. Optional 5 in 1 antenna extension (A80701)
4. Boat Wi-Fi (antennas supplied)
5. Compatible MFD (e.g.: Axiom XL)
6. YachtSense™ Link Marine Cloud Router
7. Mandatory grounding connection
8. 12 V / 24 V dc router power supply

9. RayNet connection to MFD (direct or via Raymarine network switch)
10. Router output channel connections (rated at 200 mA; for controlling devices via standard automotive relays)
11. Router input channel connections (detect switch states and monitor voltage.)
12. DeviceNet to SeaTalkng<sup>®</sup> connection to MFD (via an adaptor cable, e.g.: A06075).
13. Other Raymarine products connected via RayNet (direct or via a Raymarine network switch)
14. 12 V dc SeaTalkng<sup>®</sup> power supply (with 5 A fuse)
15. SeaTalkng<sup>®</sup> backbone (requires its own 12 V power supply)

5. Dock WLAN A (External dock Wi-Fi antenna connection)
6. Dock WLAN B (External dock Wi-Fi antenna connection)
7. Boat Wi-Fi B (Internal boat Wi-Fi antenna connection)
8. Power connection
9. SeaTalkng<sup>®</sup> connection
10. RayNet connections
11. Input connections
12. Output connections
13. Dedicated grounding connection — this MUST be connected to a suitable grounding point; refer to: [p.39 — Grounding connection](#)

## 5.3 Connections overview

The YachtSense<sup>™</sup> Link includes the following connections:

### Note:

- The router is supplied with protective caps fitted to the antenna connections, RayNet connections, Input and Output connections, and the SeaTalkng<sup>®</sup> connection.
- The protective caps should remain in place until connections are made. If a connection is not required then the protective cap should not be removed.

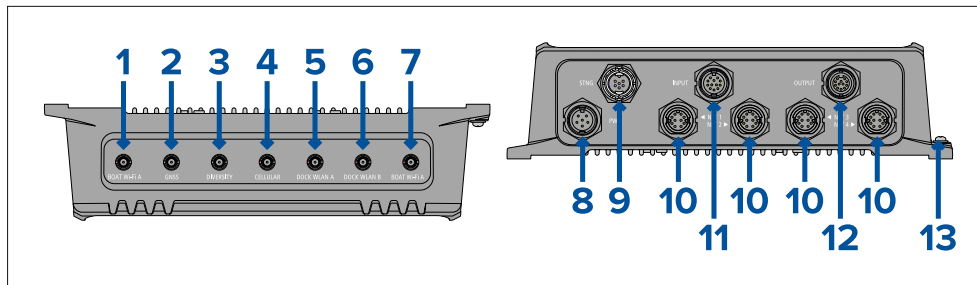

1. Boat Wi-Fi A (Internal boat Wi-Fi antenna connection)
2. GNSS (GPS/GLONASS antenna connection)
3. Diversity (Secondary cellular antenna connection)
4. Cellular (Primary cellular antenna connection)

## 5.4 MFD connections

Raymarine MFDs require both a RayNet (SeaTalkhs<sup>®</sup>) and SeaTalkng<sup>®</sup> connection to the router.

### Note:

The router is compatible with Raymarine MFDs running LightHouse<sup>™</sup> version 4.0 and above.

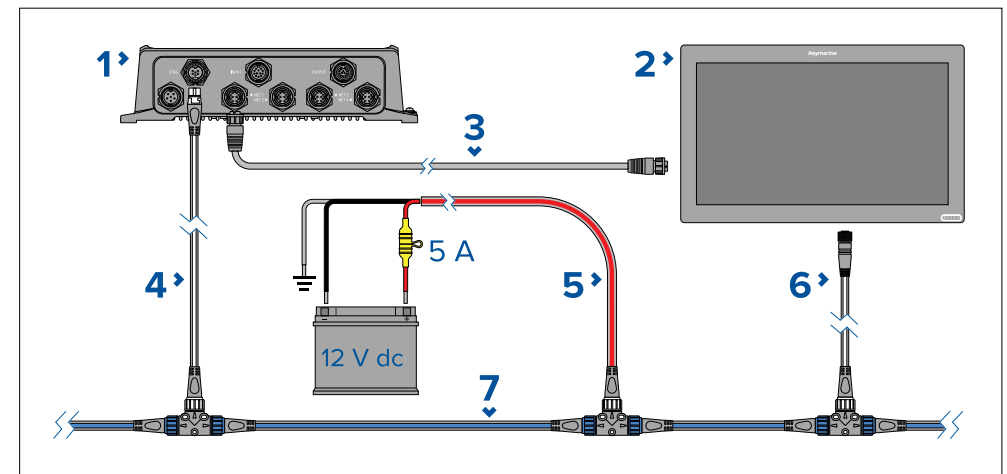

1. YachtSense<sup>™</sup> Link router
2. Axiom<sup>™</sup> / Axiom<sup>™</sup>+ / Axiom<sup>™</sup> Pro / Axiom<sup>™</sup> XL MFD.

3. RayNet to RayNet (SeaTalkhs<sup>®</sup>) network cable.
4. SeaTalkng<sup>®</sup> spur cable.
5. SeaTalkng<sup>®</sup> power cable (supplying 12 V dc power. 5 amp inline fuse is required).
6. SeaTalkng<sup>®</sup> to DeviceNet spur cable.
7. SeaTalkng<sup>®</sup> backbone.

## 5.5 YachtSense ecosystem

YachtSense™ is Raymarine's digital monitoring and control solution. The YachtSense™ ecosystem enables on and off boat monitoring and control of connected vessel systems and data. On boat monitoring and control can be achieved using a Raymarine Axiom MFD or the Raymarine app installed on a mobile phone or tablet. Off boat monitoring and control can be achieved using the Raymarine app. Off boat monitoring and control requires a valid premium subscription.

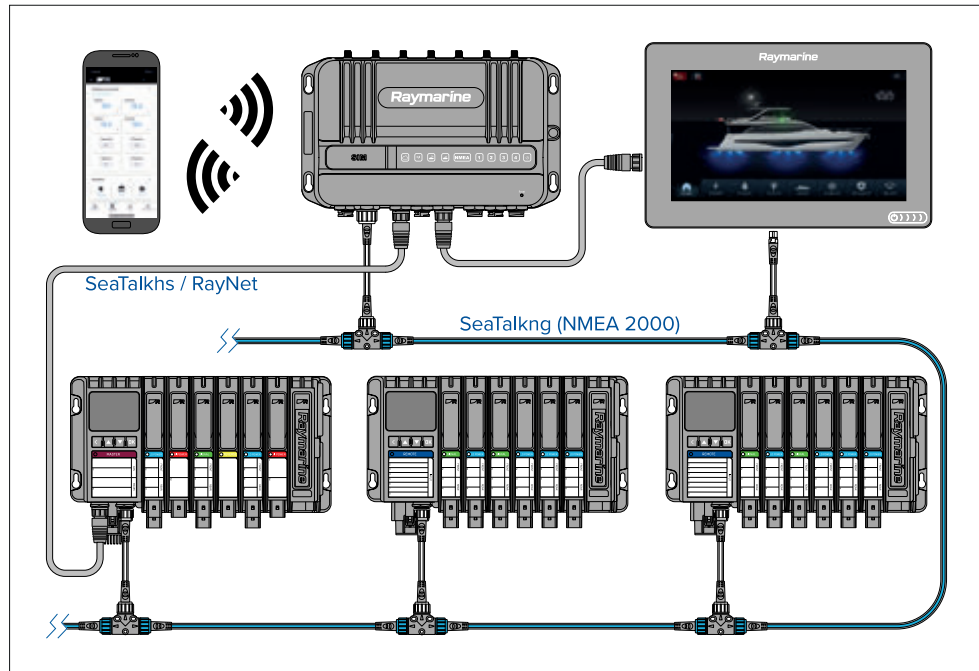

The full YachtSense™ ecosystem consist of:

- YachtSense Link router

- YachtSense Digital Control System
- Raymarine mobile app
- Premium app subscription (required for off-boat connectivity)
- Axiom MFDs

### Note:

- The YachtSense™ Link router must be connected to the same SeaTalkng backbone and as the YachtSense Digital Control System and any MFDs.
- The router also requires a RayNet connection to the YachtSense Digital Control System's master module and any MFDs.

## 5.6 Power connection

The supplied power cable must be connected to a 12 V dc or 24 V dc power supply, this can be achieved by connecting directly to a battery, or via the distribution panel.

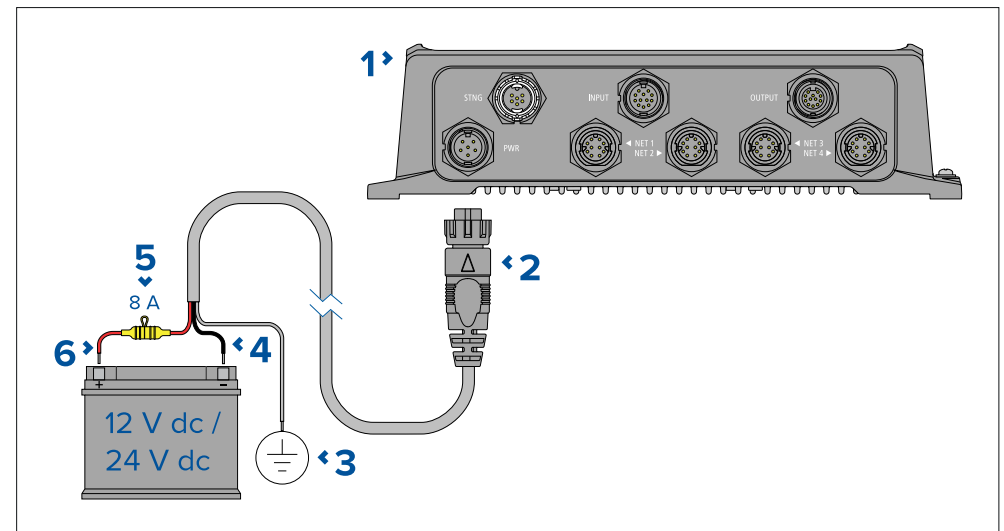

1. YachtSense™ Link
2. Power cable (supplied)
3. Drain wire connects to vessel's RF ground point, if no ground point is available connect to the battery negative (-) terminal.
4. Negative wire connects to power supply negative (-) terminal.

5. Waterproof fuse holder with 8 A fuse must be fitted
6. Positive (Red) wire connects to power supply positive (+) terminal.

### In-line fuse and thermal breaker ratings

The following in-line fuse and thermal breaker ratings apply to your product:

In-line fuse rating	Thermal breaker rating
8 A	8 A

#### Note:

- The suitable fuse rating for the thermal breaker is dependent on the number of devices you are connecting. If in doubt consult an authorized Raymarine dealer.
- Your product's power cable may have an in-line fuse fitted, if not then you must add an in-line fuse / breaker to the positive wire of your product's power connection.

### Caution: Power supply protection

When installing this product ensure the power source is adequately protected by means of a suitably-rated fuse or thermal circuit breaker.

### Power distribution

Recommendations and best practice.

- The product is supplied with a power cable, either as a separate item or a captive cable permanently attached to the product. Only use the power cable supplied with the product. Do NOT use a power cable designed for, or supplied with, a different product.
- Refer to the *Power connection* section for more information on how to identify the wires in your product's power cable, and where to connect them.
- See below for more information on implementation for some common power distribution scenarios:

### Important:

- When planning and wiring, take into consideration other products in your system, some of which (e.g. sonar modules) may place large power demand peaks on the vessel's electrical system, which may impact the voltage available to other products during the peaks.
- The information provided below is for guidance only, to help protect your product. It covers common vessel power arrangements, but does NOT cover every scenario. If you are unsure how to provide the correct level of protection, please consult an authorized dealer or a suitably qualified professional marine electrician.

### Implementation – connection to distribution panel (Recommended)

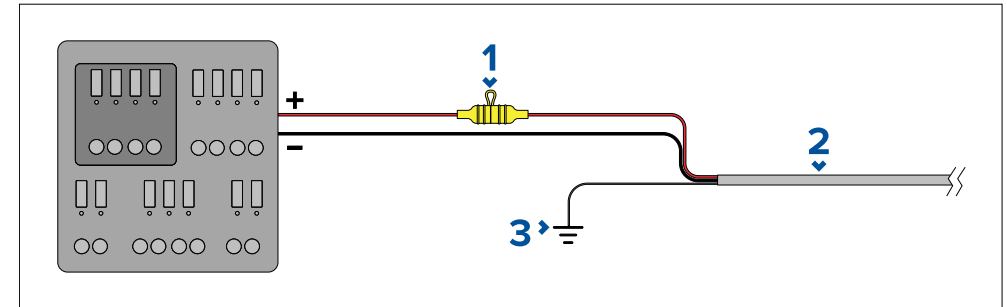

1	Waterproof fuse holder containing a suitably-rated inline fuse must be fitted. For suitable fuse rating, refer to: <i>In-line fuse and thermal breaker ratings</i> .
2	Product power cable.
3	Drain wire connection point.

- It is recommended that the supplied power cable is connected to a suitable breaker or switch on the vessel's distribution panel or factory-fitted power distribution point.
- The distribution point should be fed from the vessel's primary power source by 8 AWG (8.36 mm<sup>2</sup>) cable.
- Ideally, all equipment should be wired to individual suitably-rated thermal breakers or fuses, with appropriate circuit protection. Where this is not possible and more than 1 item of equipment shares a breaker, use individual in-line fuses for each power circuit to provide the necessary protection.

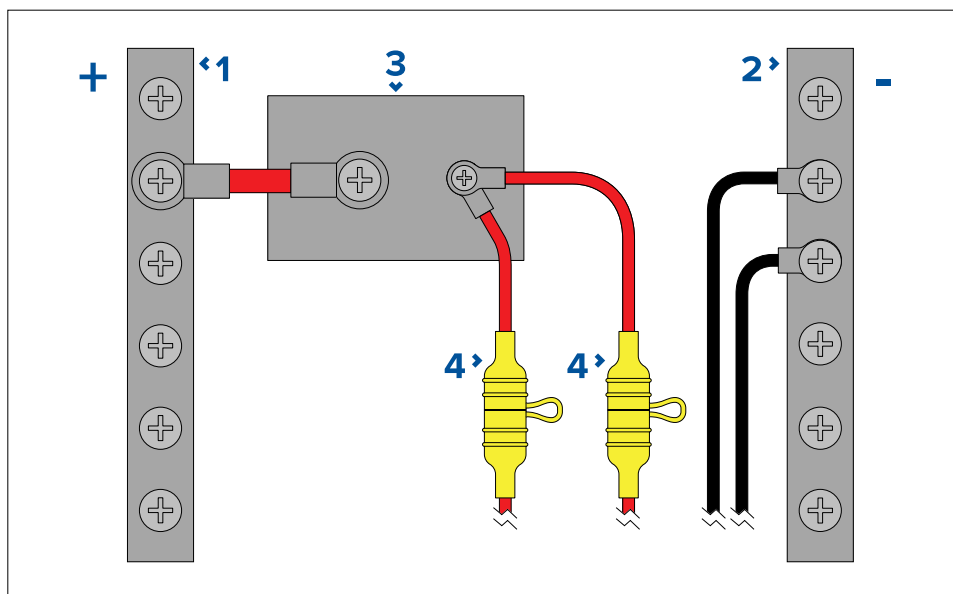

1	Positive (+) bar
2	Negative (-) bar
3	Circuit breaker
4	Waterproof fuse holder containing a suitably-rated inline fuse must be fitted. For suitable fuse rating, refer to: <i>In-line fuse and thermal breaker ratings</i> .

- If the power cable is NOT supplied with a fitted inline fuse, you MUST fit a suitably rated fuse or breaker between the red wire and the battery's positive terminal.
- Refer to the inline fuse ratings provided in the product's documentation.
- If you need to extend the length of the power cable supplied with your product, ensure you observe the dedicated *Power cable extensions* advice provided in the product's documentation.

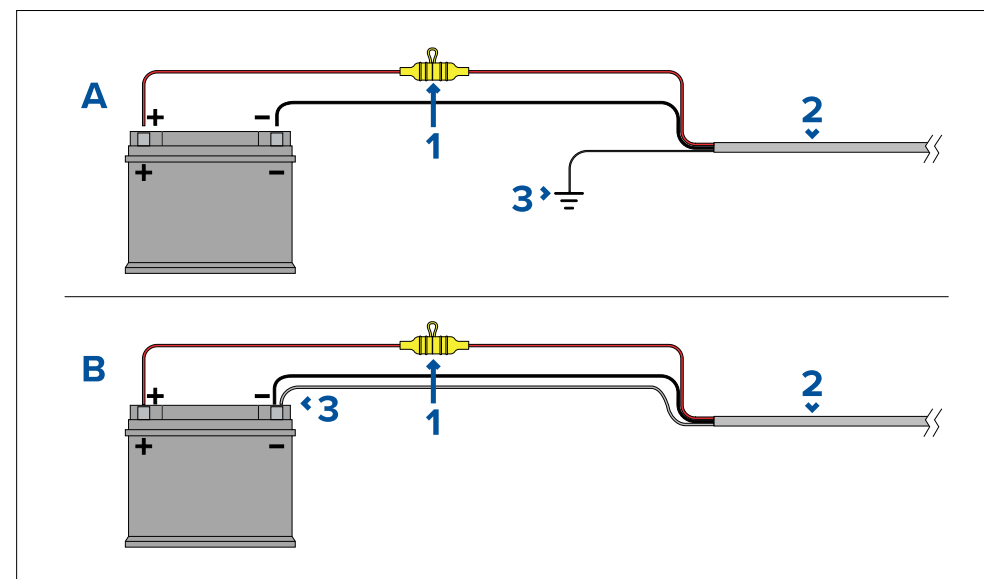

1	Waterproof fuse holder containing a suitably-rated inline fuse must be fitted. For suitable fuse rating, refer to: <i>In-line fuse and thermal breaker ratings</i> .
2	Product power cable.
3	Drain wire connection point.

#### Battery connection scenario A:

Suitable for a vessel with a common RF ground point. In this scenario, if your product's power cable is supplied with a separate drain wire then it should be connected to the vessel's common ground point.

#### Battery connection scenario B:

Suitable for a vessel without a common grounding point. In this case, if your product's power cable is supplied with a separate drain wire then it should be connected directly to the battery's negative terminal.

#### Important:

Observe the recommended fuse / breaker ratings provided in the product's documentation, however be aware that the suitable fuse / breaker rating is dependent on the number of devices being connected.

#### Implementation — direct connection to battery

- Where connection to a power distribution panel is not possible, the power cable supplied with your product may be connected directly to the vessel's battery, via a suitably rated fuse or breaker.
- The power cable supplied with your product may NOT include a separate drain wire. If this is the case, only the power cable's red and black wires need to be connected.

## Power cable extension

If you need to extend the length of the power cable supplied with your product, ensure you observe the following advice:

- The power cable for each unit in your system should be run as a separate, single length of 2-wire cable from the unit to the vessel's battery or distribution panel.
- Ensure that the extension cable is of a sufficient gauge for the supply voltage and the total load of the device and the length of the cable run. Refer to the following table for typical **minimum** power cable wire gauges.

Cable length in meters (feet)	Wire gauge in AWG (mm <sup>2</sup> ) for 12 V supply	Wire gauge in AWG (mm <sup>2</sup> ) for 24 V supply
<8 (<25)	16 (1.31 mm <sup>2</sup> )	18 (0.82 mm <sup>2</sup> )
16 (50)	14 (2.08 mm <sup>2</sup> )	18 (0.82 mm <sup>2</sup> )
24 (75)	12 (3.31 mm <sup>2</sup> )	16 (1.31 mm <sup>2</sup> )
>32 (>100)	10 (5.26 mm <sup>2</sup> )	16 (1.31 mm <sup>2</sup> )

### Important:

Be aware that some products in your system (such as sonar modules) can create voltage peaks at certain times, which may impact the voltage available to other products during the peaks.

**Important:** To ensure power cables (including any extension) are of a sufficient gauge, ensure that there is a continuous **minimum** voltage of **10.8 V dc** at the end of the cable where it enters the product's power connector, even with a fully flat battery at 11 V dc. (Do not assume that a flat battery is at 0 V dc. Due to the discharge profile and internal chemistry of batteries, the current drops much faster than the voltage. A "fully flat" battery still shows a positive voltage, even if it doesn't have enough current to power your device.)

## Grounding

Ensure that you observe any additional grounding advice provided in the product's documentation.

### More information

It is recommended that best practice is observed in all vessel electrical installations, as detailed in the following standards:

- BMEA Code of Practice for Electrical and Electronic Installations in Boats
- NMEA 0400 Installation Standard
- ABYC E-11 AC & DC Electrical Systems on Boats
- ABYC A-31 Battery chargers and Inverters
- ABYC TE-4 Lightning Protection



### Warning: Product grounding

Before applying power to this product, ensure it has been correctly grounded, in accordance with the instructions provided.



### Warning: Positive ground systems

Do not connect this unit to a system which has positive grounding.

## 5.7 Grounding connection

The YachtSense™ Link unit includes a dedicated grounding point, which **MUST** be connected as described below.

### Important:

Connect the product's grounding point to your vessel's common RF ground. **On vessels without an RF ground system**, connect the product's grounding point directly to the vessel's negative battery terminal. This dedicated grounding point is **NOT** an optional connection.

The vessel's dc power system should be either:

- Negative grounded ("bonded"), with the negative battery terminal connected to the vessel's RF ground.
- Floating, with neither battery terminal connected to the vessel's ground.

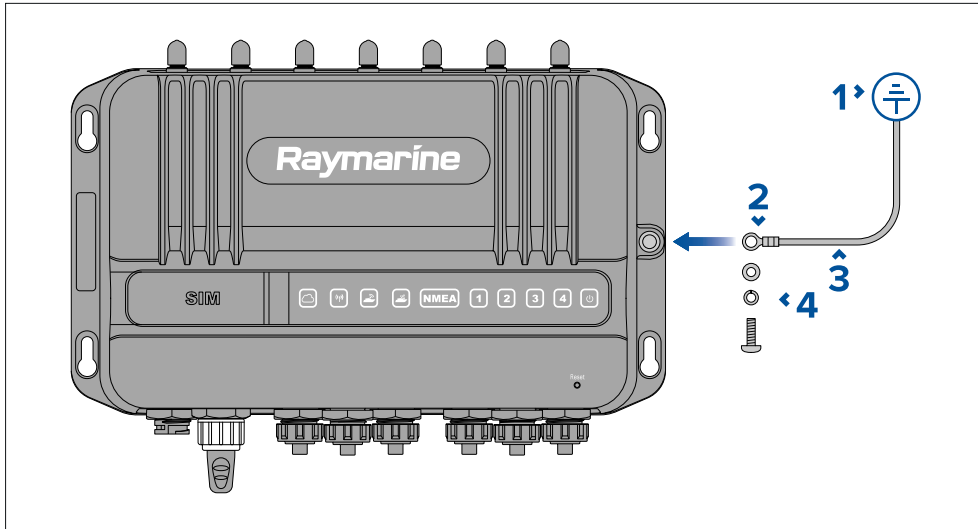

1. Vessel grounding point.
2. M3 size ring crimp (not supplied).
3. Grounding strap connected to vessel RF ground (not supplied).
4. Grounding screw and washers (supplied pre-fitted to the unit).

To connect the grounding point, an M3 ring crimp and suitable cable is required to create a grounding strap.

The grounding cable is connected to the product using the M3 screw and washers that are supplied pre-fitted to the product's grounding point.

The preferred minimum requirement for the path to the vessel's ground (bonded or non-bonded) is via a flat tinned copper braid, with a 30 A rating or greater. If this is not possible, an equivalent stranded wire conductor may be used, rated as follows:

- for runs of <1 m (3 ft), use 6 mm<sup>2</sup> (10 AWG) or greater.
- for runs of >1 m (3 ft), use 8 mm<sup>2</sup> (8 AWG) or greater.

In any grounding system, always keep the length of connecting braid or wires as short as possible.

## 5.8 5-in-1 antenna connections

The supplied 5-in-1 antenna is connected to the antenna connections on the top of the YachtSense™ Link unit.

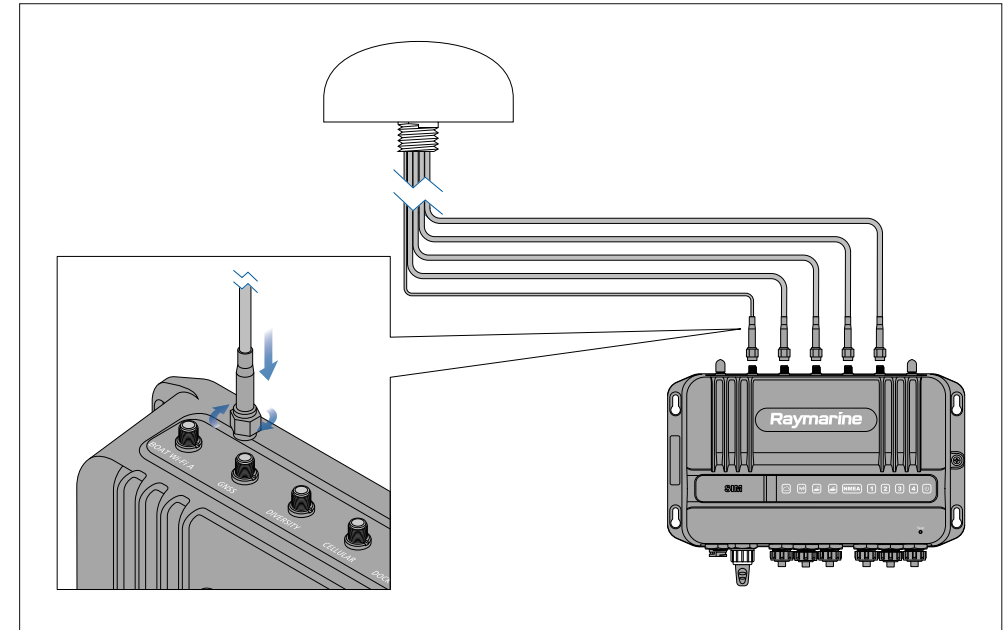

Connectors and cables are labelled appropriately. Connections are made by pushing the relevant cable connector over the relevant connector on the router and securing by turning the connector nut clockwise until tight.

The antenna's cable is 5 m (16.4 ft) in length. **This length can be extended if required using the optional 5 m (16.4 ft) extension cable (A80701), for a total cable length (including the antenna's supplied cable) of 10 m (32.8 ft).**



## Antenna extension kit

The 5 m (16.4 ft) antenna cables on the supplied 5-in-1 antenna can be extended by 5 m (16.4 ft), using the antenna cable extension kit (A80701). Including the antenna extension cable kit, the total antenna cable length is 10 m (32.8 ft).

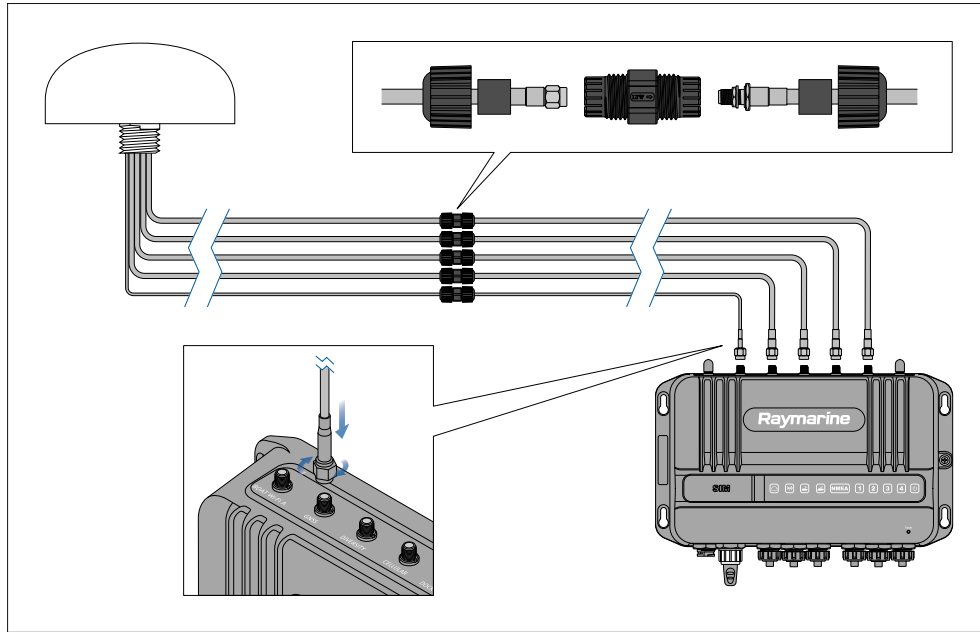

The extension kit consists of:

- 4 x extension cables for the **DOCK WLAN A**, **DOCK WLAN B**, **Cellular** and **Diversity** connections.
- 1 x extension cable for the **GNSS** (GPS) connection (the thinner cable).
- 5 x waterproof cable joiners.
- 2 x thicker sleeves for use with the waterproof cable joiner on the GNSS (GPS) cable.

The supplied 5-in-1 antenna cable connectors are connected to the opposing connector on the relevant extension cable, the cable joiner is used over this connection to provide a watertight seal.

The opposite end of the extension cable is then connected to the relevant connection on the router.

Refer to the instruction sheet provided with the cable extension kit for details on how to assemble the waterproof cable joiners.

## 5.9 Boat Wi-Fi antenna connections

The supplied Wi-Fi antennas are connected to the **BOAT** Wi-Fi connections on the top of the YachtSense™ Link.

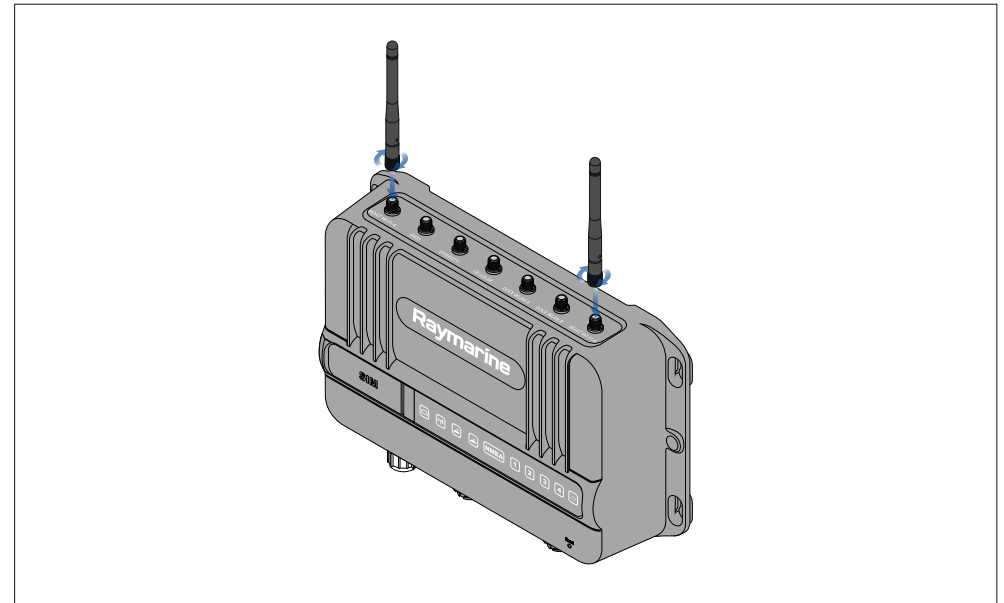

Connect the antennas by screwing them in clockwise until hand tight.

## 5.10 RayNet connections

Up to 4 RayNet devices can be connected to the YachtSense™ Link using the RayNet connections. RayNet networks can also be created or expanded by connecting the YachtSense™ Link to a network switch such as the HS5.

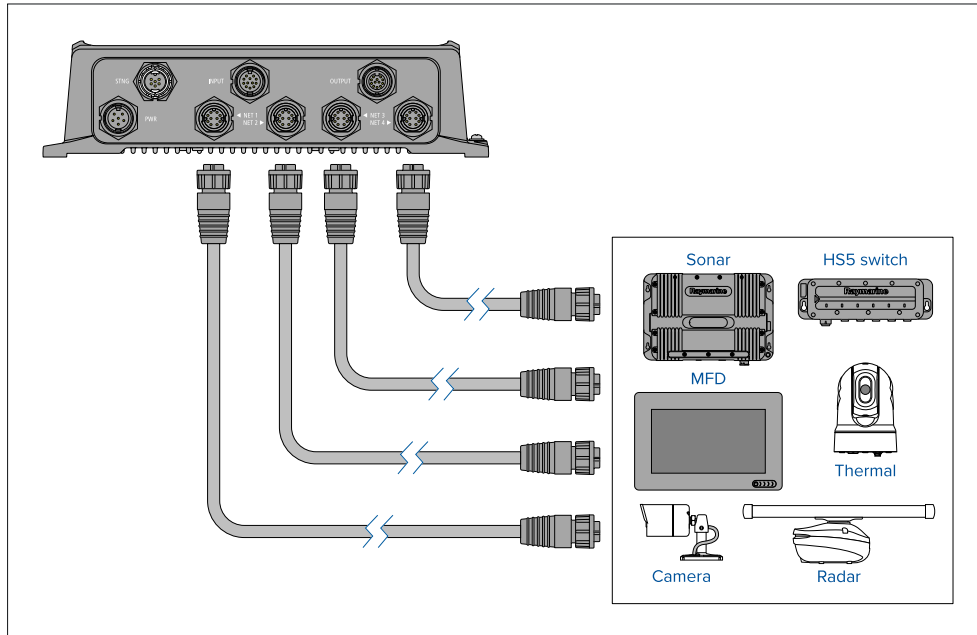

## 5.11 Third party hardware with companion apps

To guarantee optimum wireless network performance the router does not bridge wired (RayNet) and wireless (Boat Wi-Fi) connections, and instead routes packets between the two networks.

This means that:

- Third-party hardware that uses mDNS can use a wired (RayNet) connection to the router and be discoverable by its companion app that is installed on a device connected to the router's wireless (Boat Wi-Fi) connection.
- Third-party hardware that does not use mDNS requires a wireless (Boat Wi-Fi) connection to the router for it to be discoverable by its companion app.

- Third-party hardware where the companion app supports fixed IP addressing for discovery can use wired (RayNet) connection to the router.

## 5.12 SeaTalkng connection

The router should be connected to SeaTalkng® backbone using the supplied SeaTalkng® spur cable. Connection to a SeaTalkng® backbone enables compatible data to be received and transmitted by the router. The SeaTalkng® connection also enables communications with Raymarine Axiom™ MFDs and Raymarine YachtSense™ Digital Control Systems.

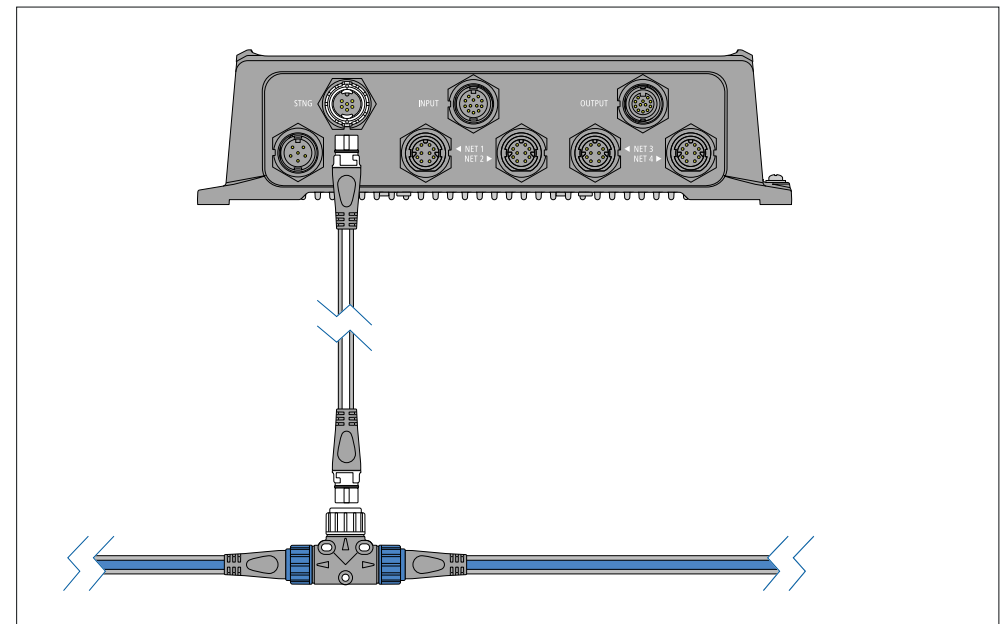

### Note:

The SeaTalkng® backbone requires a dedicated 12 V dc power supply and is not supplied power from the router.

## 5.13 Input and output channels



### Warning: Input and output channels

- The router's input and output channels enable creation of a simple digital monitoring / control system. As device connections are outside of Raymarine's control the company will not be held liable for damage or injury caused due to incorrect connections.
- Input and output device connections should only be carried out by a competent person familiar with vessel digital switching systems.
- The Router's output channels are rated at 200 mA and are only intended to be connected to devices via standard automotive relays.
- If in any doubt or for further advice please contact Raymarine Technical Support.

## 5.14 Input channel connection wiring

The router's I/O channels 1 to 4 are input channels. The supplied input cable (included in kit: R70800) must be used to connect devices to the router's input connector.

### Important:

- The negative power wire (0 V return) of the YachtSense™ Link's power cable must be connected to the same power supply negative as all connected input devices.
- Each device must have a positive supply connection to a positive channel wire on the input cable and a negative supply connection to the input cable's common negative wire.

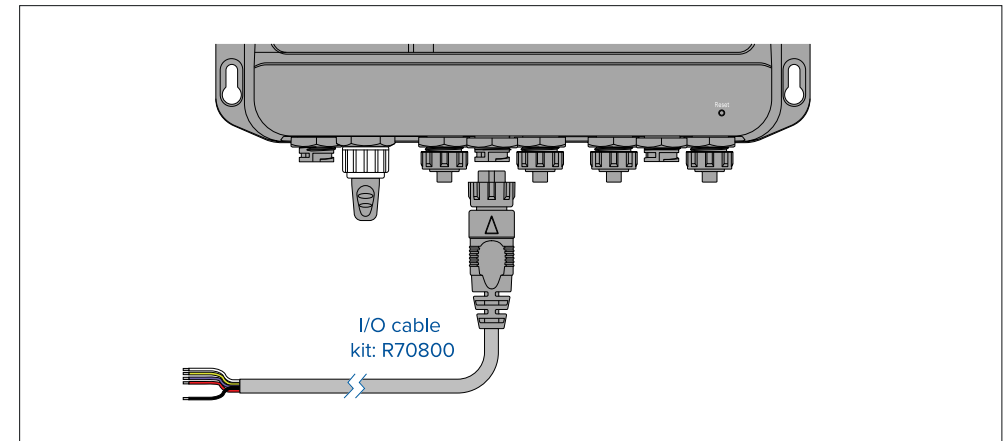

### Input cable signal wires

- White = Channel 1 + (positive)
- Yellow = Channel 2 + (positive)
- Purple = Channel 3 + (positive)
- Red = Channel 4 + (positive)
- Black = Common - (negative)

The input channels can be monitored from the YachtSense™ Link web interface or from the Raymarine app.

### Input channel connections

The input channels can be configured as follows:

- Analog — voltage monitoring from 0 V dc to supply voltage.
- Digital — switch state detection when connected between channel and supply voltage. Switches can be normally open or normally closed.

The input channels are configured from the router web interface's Channels configuration page: **ADVANCED SETTINGS > Inputs & Outputs > Channels configuration.**

### Note:

- The input channel cannot detect switch state on switches that are switched to negative supply.
- All connections to positive voltage supply should be fused appropriately.

When configured for digital switch detection an input channel can be used to wake the router from low power mode. Refer to the Power management page of the router's web interface for settings.

The input channels are protected up to 32 V dc (in case of inadvertent connection) and are opto isolated when driven from another device or supply.

The input channel will automatically switch between low voltage (0 V dc to 8 V dc) and High voltage (8 V dc to supply voltage). The two thresholds are for the application of hysteresis.

### Example connections

#### Example — Switch detection (Digital)

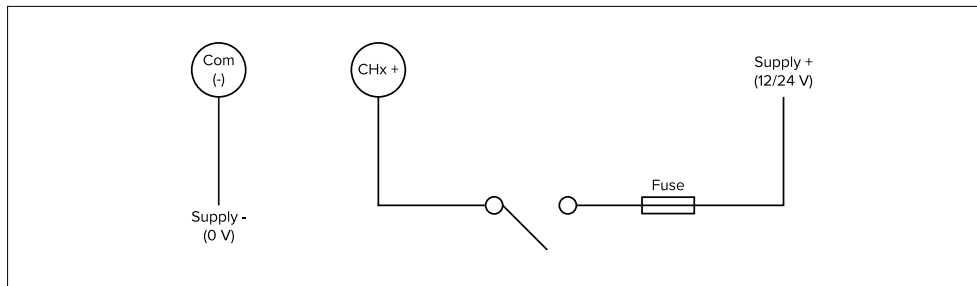

#### Example — Voltage monitor (Analog)

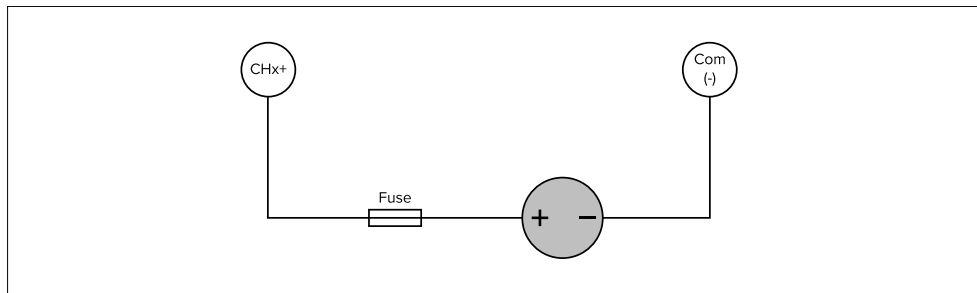

## 5.15 Output channel wiring

The router's I/O channels 5 to 8 are output channels. The supplied output cable (included in kit: R70800) must be used to connect automotive relays to the router's output connector.

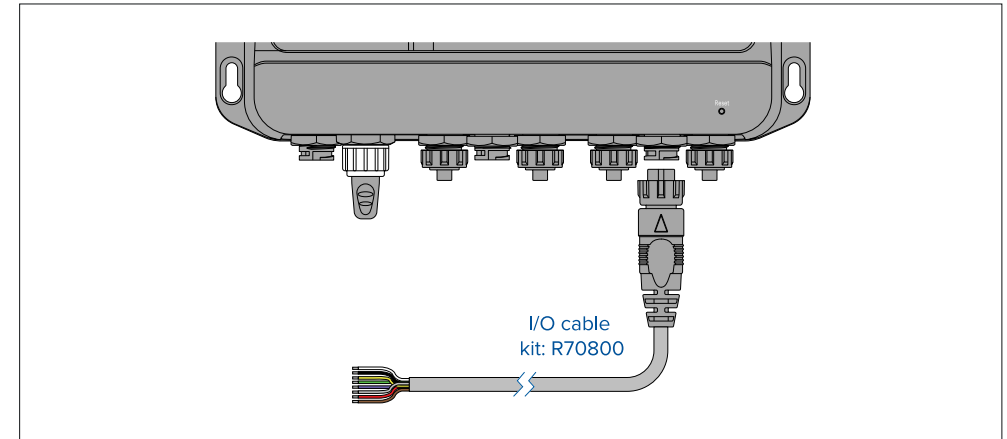

### Output cable signal wires

- White = Output 1 Normally open terminal (N/O)
- Black = Output 1 Common terminal (COM)
- Yellow = Output 2 Normally open terminal (N/O)
- Green = Output 2 Common terminal (COM)
- Purple = Output 3 Normally open terminal (N/O)
- Gray = Output 3 Common terminal (COM)
- Red = Output 4 Normally open terminal (N/O)
- Brown = Output 4 Common terminal (COM)

The output channels can be controlled from the YachtSense™ Link web interface or from the Raymarine app.

## Output channel connections

The output connection includes 4 configurable output channels. Output channels are intended to be connected to devices via an automotive relay. It is NOT intended that devices are connected directly to the output channels.

### Note:

- It is recommended that you use a relay with a built in protection diode.
- The router's output channels do NOT supply voltage to devices. The output channel's terminals (N/O and COM) are shorted together using internal relays within the router to complete a circuit.

The output channels voltage characteristics are as follows:

- Maximum throughput per channel is 200 mA.
- Voltage protection up to 32 V dc (in case of inadvertent connections).
- Each output channel has a 200 mA internal thermal fuse.

The router's output channels (Channels 5 to 8) can be used to wake connected devices or systems that have a wake-on-power input feature. When the router is woken from low power mode the connected device will also be woken.

Refer to the Power management details: [p.57 – Power management page](#)

### Note:

The connection diagram is provided as an example of how the to connect an output channel (items 1 and 2) via a relay (5) to control a device. The other components in the diagram may not reflect your installation and sound electrical judgement should always be used when attempting to connect the router's output channels.

## Example automotive 4 or 5 pin relay type B connection diagram

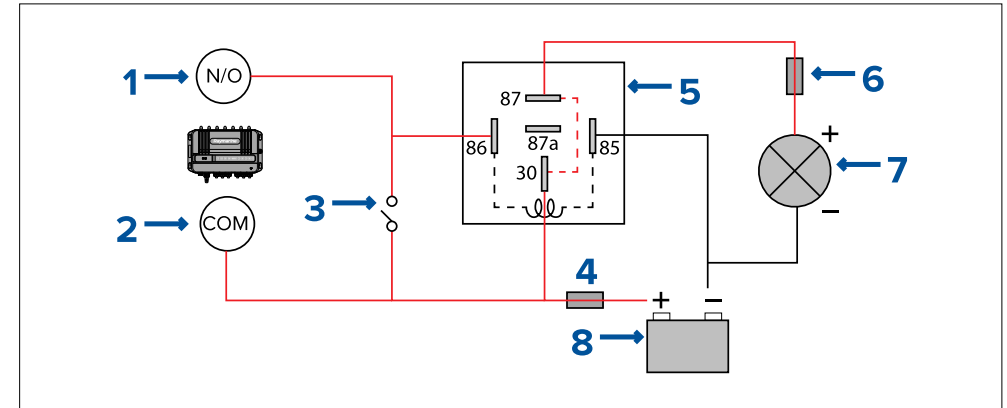

1. Router output channel Normally Open terminal (e.g.: Output 1 White wire)
2. Router output channel Common terminal (e.g.: Output 1 Black wire)
3. Parallel switch
4. Suitably rated power supply fuse
5. Automotive 5 pin relay
  - **30** — High power feed
  - **86** — Relay coil feed (Trigger wire)
  - **85** — Relay coil ground
  - **87** — High power output (normally open contact)
  - **87a** — High power output (normally closed contact)
6. Suitably rated device fuse
7. Device (e.g.: lighting)
8. Power supply

# CHAPTER 6: OPERATIONS

## CHAPTER CONTENTS

- [6.1 Getting started — page 47](#)
- [6.2 Link your router \(Onboarding\) — page 52](#)
- [6.3 Status page — page 53](#)
- [6.4 Basic settings — page 53](#)
- [6.5 Connected devices page — page 55](#)
- [6.6 Advanced settings — page 55](#)
- [6.7 Help — page 59](#)
- [6.8 YachtSense Link router account transfer / ownership transfer — page 59](#)
- [6.9 Boat system and router removal \(Offboarding\) — page 59](#)

## 6.1 Getting started

### Accessing the web interface from a Raymarine MFD

The router's settings are accessed using the built-in web interface. The web interface can be accessed using a wired connection to a Raymarine MFD running the LightHouse™ 4 operating system..

#### Important:

Ensure that the MFD and router are connected over RayNet ethernet (SeaTalkhs®), and that they are both connected to the same NMEA 2000 (SeaTalkng® backbone).

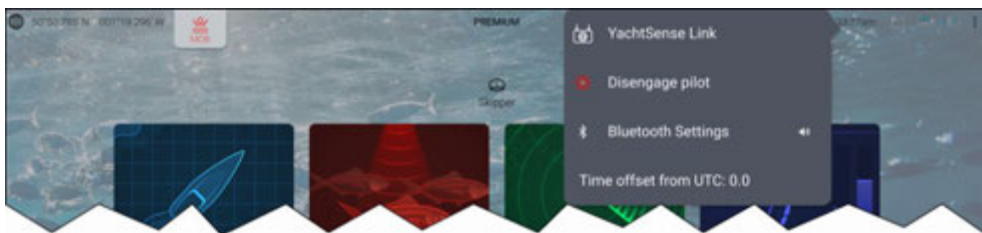

From the MFD's homescreen:

1. Select the status area on the top right of the screen.
2. Select YachtSense Link from the pop-over options.

The status page is displayed:

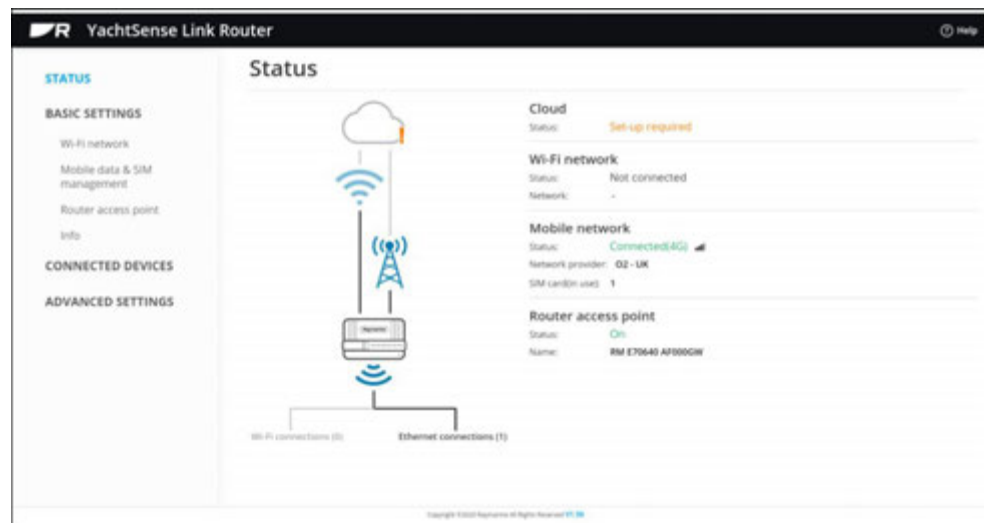

The router's web interface can also be accessed from the Network menu: Homescreen > Settings > Network by selecting Raymarine Yachtsense Link from the list and then selecting Calibrate from the pop-over options.

### Accessing the web interface using a wired connection

The router's settings are accessed using the built in web interface. The web interface can be accessed using a wired connection to a personal computer.

#### Important:

Ensure that your personal computer is configured to be assigned an IP address automatically.

1. Ensure the router has been supplied power following the power connection details. [p.36 – Power connection](#)
2. Connect the supplied RayNet to RJ45 cable to one of the router's network ports.
3. Connect the other end of the RayNet to RJ45 cable to a personal computer.
4. Turn on the router's power supply.
5. Wait for the router to boot up and for your personal computer's network connection to be established.
6. Enter '<http://yachtsense.raymarine.com>' into your web browser's address bar and press Enter/Return.

#### Important:

**Supported browsers** — The web interface can be accessed using the following supported browsers: Chrome, Firefox, Edge and Safari. Internet explorer (IE) is NOT supported.

The status page will be displayed

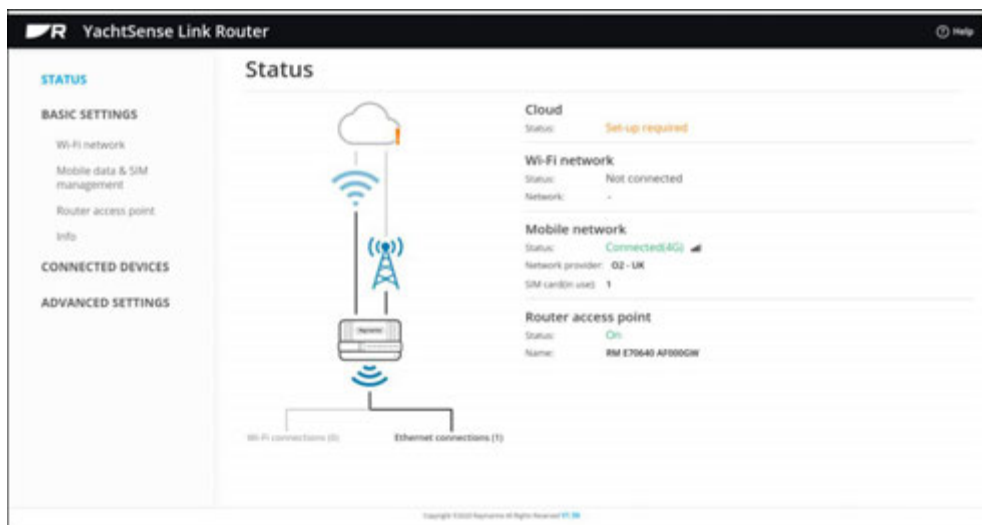

## Accessing the web interface using a Wi-Fi connection

The router's settings are accessed using the built in web interface. The web interface can be accessed using a wireless connection to a mobile device or personal computer.

### Important:

- **Supported browsers** — The web interface can be accessed using the following supported browsers: Chrome, Firefox, Edge and Safari. **Internet explorer (IE) is NOT supported.** If you experience problems using generic browsers on a mobile device try using one of the listed supported browsers instead.
- **IP address** — Your device's IP address must be in the same range as the router's IP address. By default most Wi-Fi and ethernet connections are configured to obtain an IP address automatically. This will ensure your device's and router's IP address are in the same range. If your device is assigned a static IP address then it must be in the same range as the router's IP address. Your router's IP address can be found on an MFD's Network settings tab: Homescreen > Settings > Network. Then select **Raymarine Yachtsense Link** from the list of network devices, and select the Product Info option, alternatively you could use a network discovery tool to identify the router's IP address.
- **VPNs** — Some VPNs can block access to the router's web interface. If you use a VPN ensure it is disconnected before trying to access the web interface.

### Example credentials label





## Note:

The details in the illustration above are an example only and do not reflect the actual credentials for your router.

1. **Default wireless details** — Wi-Fi credentials used for connecting mobile devices to the router's Wi-Fi network.
2. **Default access to settings** — Log in details for the router's settings web interface.

To access the web interface using a Wi-Fi connection follow the steps below:

1. Ensure the router has been supplied power following the power connection details. [p.36 — Power connection](#)
2. Turn on the router's power supply.
3. Wait for the router to complete its boot up sequence.
4. Connect your mobile device to the router's Wi-Fi network using the SSID and password located on the Credentials label on the side of the router (See item 1 in the above illustration).
5. Open a web browser on your connected mobile device.
6. <sup>(1)</sup>Enter '<http://yachtsense.raymarine.com>' or your router's IP address into your web browser's address bar and press Enter/Return.

The status page is displayed.

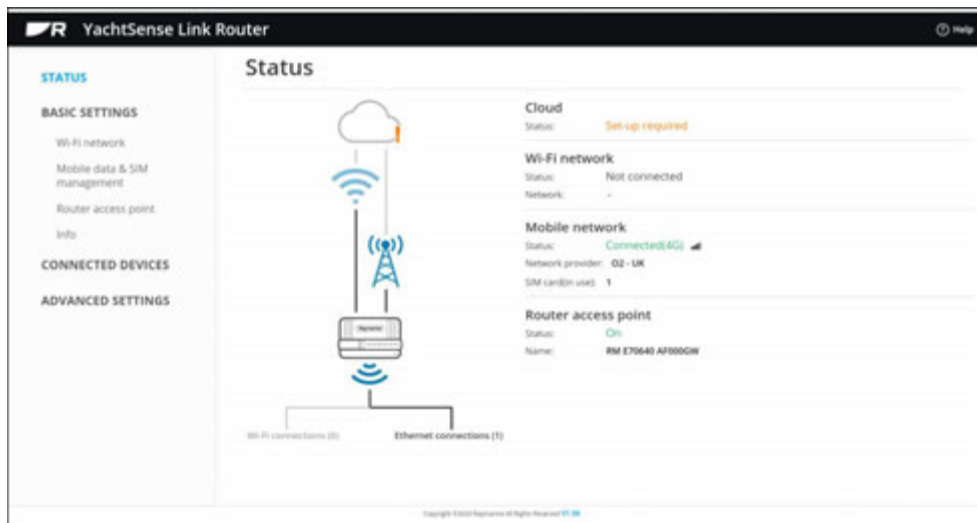

## Accessing settings pages

From the router's status page you can access all of the routers settings. The first time you click a link you will be requested to log in to the router.

1. Click a link on the left hand side of the Status page.

*You can also select the Wi-Fi network, Mobile network and Router access point headings or icons to access the relevant settings page.*

2. Enter the admin password (default password can be found on the credentials label located on the left side of the router).
3. Select OK.

The selected page will open.

## Configuring mobile data

Follow the steps below to enable the router to use your SIM card(s) mobile data plan. If 2 SIM cards are installed, the steps below should be carried out for both SIMs.

### Note:

Pre-pay / Pay As You Go (PAYG) SIM cards require activation and top up with the provider before use.

From the Mobile data and SIM management page: [Basic settings > Mobile data and SIM management](#) .

1. Select SIM1 or SIM2.
2. To allow automatic switching between SIM card when there is no network coverage or when your data limit on one SIM card has been reached, tick the relevant tick box at the top of the page.
3. To allow mobile data to be used, tick the [Mobile data](#) tick box.
4. Select the date (day of the month) that your data allowance renews, using the Router data usage cycle drop down list.
5. To set up a notification when your SIM card gets close to its data limit, tick the [Set data warning](#) tick box and then enter a value in the [Data warning](#) field.
6. To set up a notification when your SIM card reaches its data limit, tick the [Set data limit](#) tick box and then enter a value in the [Data limit](#) field.
7. If the APN (Access Point Name) for your provider is not listed you will need to find out what the settings are from your network provider and modify an existing entry with the details.

8. To save all changes, select the **Save** button located at the top of the page.

### Manual APN settings configuration

When you power up the router after inserting a SIM card the APN settings may be configured automatically. However if you

Correct APN settings for your SIM provider can be found by searching the internet for <provider name> APN settings e.g.: Giff Gaff APN settings. There may be different settings for monthly contract SIMs and pay as you go (PAYG) SIMs.

### Connecting to an available Wi-Fi network

Follow the steps below to connect to an external Wi-Fi network (e.g.: the Wi-Fi hotspot at your marina).

From the **Wi-Fi connection** page: **Basic settings > Wi-Fi connection**.

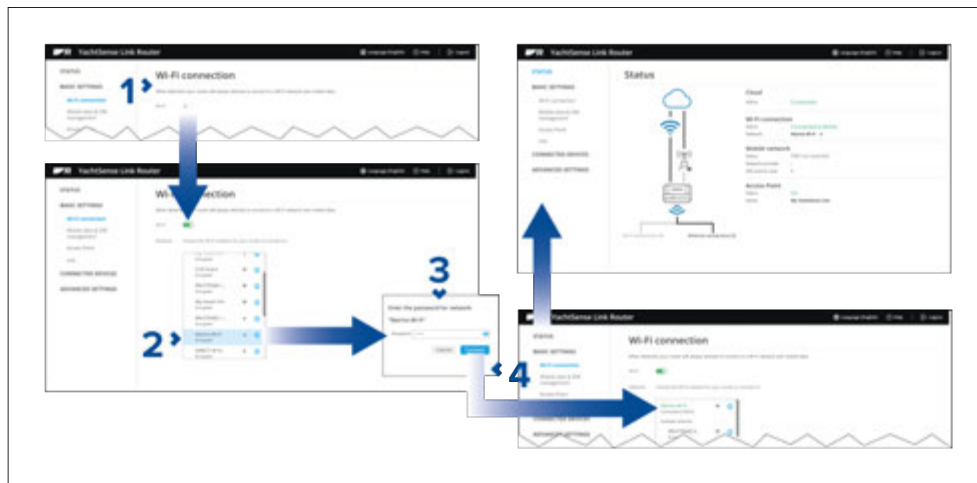

1. Enable your router's **Wi-Fi** connection using the toggle switch.
2. Select the **Wi-Fi** network you want to connect to from the list.

*You can select the **Info** icon next to the **Wi-Fi** network to view information about the network.*

3. Enter the password for the network in the password field.
4. Select **Connect**.

### Connecting to a Wi-Fi network manually

You can connect to a network that is not in the list but is in range, i.e.: a Wi-Fi network that is not broadcasting its SSID.

1. Select **Add network**.
2. Enter the Wi-Fi network name (SSID) in the **Network name** field.
3. Select the **Security** type from the **Security** drop down box.
4. Enter the network's password in the **Password** field.
5. Select **Connect**.

### Forgetting a saved Wi-Fi network

When the router connects to a Wi-Fi network the details will automatically be saved so that the router can connect to it automatically when it is in range. If you do not wish to connect to this Wi-Fi network in future follow the steps below to 'forget' the network.

1. Select the **Info** icon next to the saved Wi-Fi network to display the network information.
2. Select **Forget network**.

Alternatively you can also turn off automatic network connection by disabling **Connect automatically** from the **Info** dialog.

### Setting up the router's access point

Follow the steps below to set up the router's access point.

From the **Access Point** settings page: **Basic settings > Access Point**.

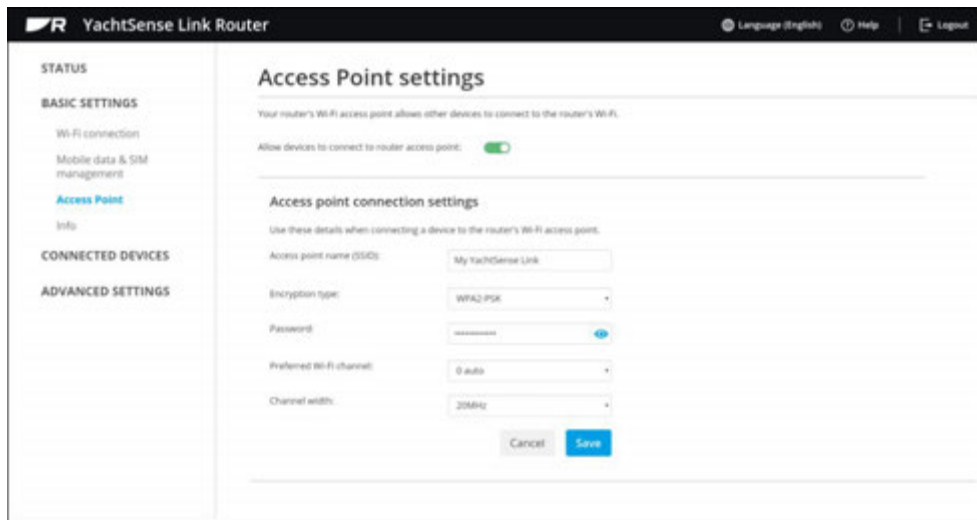

1. Enable the router's access point using the toggle switch.
2. If required, change the router's default access point connection settings.

### Important:

- The Preferred Wi-Fi channel and Channel width settings do not need to be changed unless you experience interference due to Wi-Fi congestion.
- Changing the Encryption type to No encryption is not recommended as anyone within range will be able to connect to your router.

3. Click Save.

## Network security

Your network is only as secure as its most vulnerable component. Security vulnerabilities risk allowing unintentional access to your network and its connected wireless and wired devices.

To ensure that your network is secure, as a minimum you should:

- Regularly check for security updates for all your wireless and wired networked devices.
- For applicable devices, ensure you use a reputable antivirus program with the latest virus definitions.
- Always use the strongest encryption type for your router's access point settings.

- Use a strong router access point password (i.e. a longer password such as a memorable phrase).
- Change your password periodically.
- Be cautious who you share your password with.
- If you need to write down your password, ensure it is kept in a secure place where it is not easily viewable.

## Connecting an Android device to the router's access point

Android devices can be connected to the router's Wi-Fi access point.

Open your Android device's Wi-Fi settings from the top drop down menu or via the Settings icon.

### Example Android Wi-Fi connection

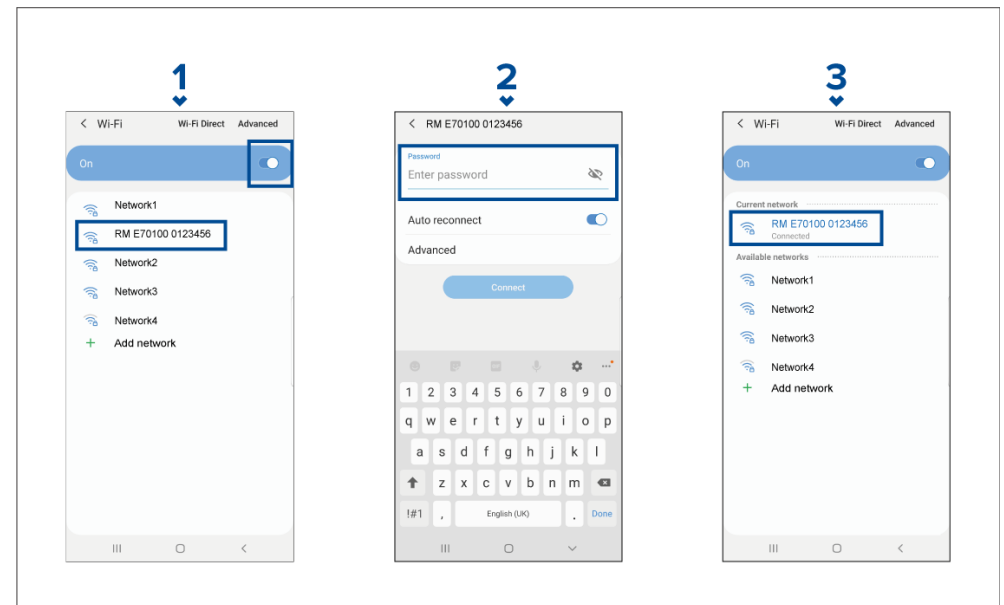

### Note:

Depending on device type, manufacturer and version of the Android operating system in use, screens and options may be different than in the example above.

1. Enable Wi-Fi by setting the toggle to on (blue) and select your router's SSID from the list of available networks.

2. Enter your router's Wi-Fi password and select **Connect**.

*The password is case sensitive.*

3. When your Android device is connected to your router's Wi-Fi it access point it will display connected under the router's SSID.

For troubleshooting advice refer to the Wi-Fi troubleshooting information on the Troubleshooting chapter [p.61 – Troubleshooting](#)

## Connecting an iOS device to the router's Wi-Fi access point

iOS devices can be connected to the router's Wi-Fi access point.

Open your iOS device's Wi-Fi settings from the top drop down menu or via Settings.

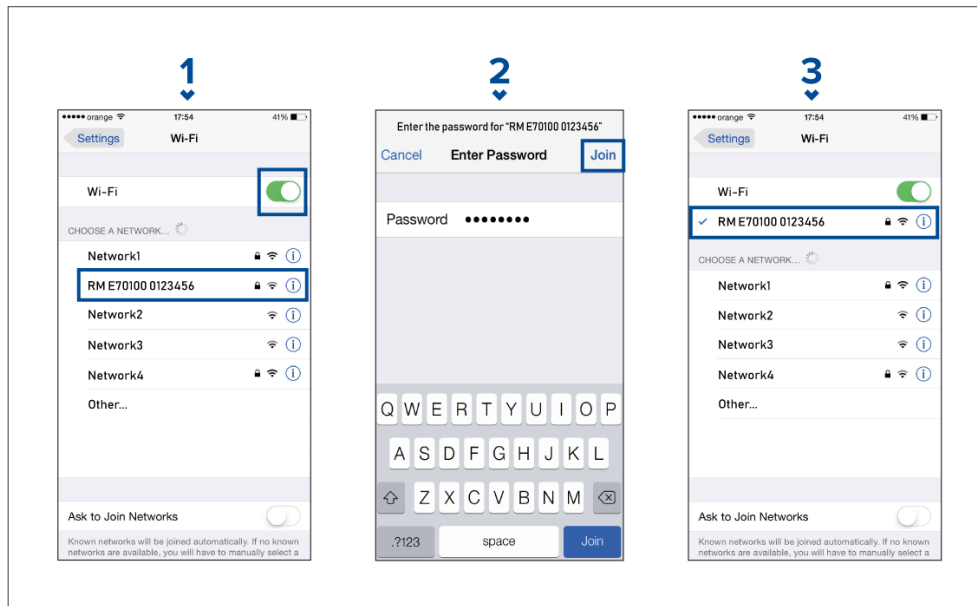

### Note:

Depending on device type, and iOS version in use, screens and options may be different than in the example above.

1. Enable Wi-Fi by setting the toggle to on (green) and select your router from the available networks.
2. Enter your router's Wi-Fi password and select **Join**.

*The password is case sensitive.*

3. When your iOS device is connected to your router's Wi-Fi it access point it will display connected under the router's SSID.

For troubleshooting advice refer to the Wi-Fi troubleshooting information on the Troubleshooting chapter [p.61 – Troubleshooting](#)

## 6.2 Link your router (Onboarding)

After setting up your YachtSense Link router and configuring its wireless networks (Wi-Fi and / or cellular (mobile) connections), you can use the Raymarine app to create a boat system and link your router to your Raymarine account. This process is known as “Onboarding”. Linking enables monitoring and control of compatible systems connected to your router using the Raymarine app.

### Note:

- **You cannot link a router that is already linked to a different account.** The linked router must first be “offboarded” by its existing owner — refer to:
  - [p.59 – YachtSense Link router account transfer / ownership transfer](#)
  - [p.59 – Boat system and router removal](#)
- If your mobile device is already connected to an MFD or a different YachtSense™ Link router it must be disconnected before another router / boat system can be added.

The linking process includes:

1. Connecting your mobile device to your YachtSense™ **Link** router's Wi-Fi connection.
2. Creating a boat system by entering your boat's name.
3. Scanning the router's QR code to connect the router to your account. The QR code can be found on the label on the side of your router or on the Info page of the router's web interface.

**The Raymarine app provides step by step instructions on how to link your router.**

## 6.3 Status page

Once you have logged in to the router's web interface the status page is displayed.

The status page provides the status the following router network connections:

- The **Cloud** section identifies the status of the router's connection to the Raymarine cloud service.
- The **Wi-Fi connection** section shows the status of the DOCK WLAN connection (e.g.: connection to marina Wi-Fi), the name of the connected network and the signal strength.
- The **Mobile network** section shows the status of the Mobile network connection, your network provider and which SIM card in use.
- The **Access point** section shows the connection status of the BOAT Wi-Fi connection and the access point's name (SSID).

The Status page also identifies the number of devices connected to the router's access point (BOAT Wi-Fi) and the wired network (devices connected to the router's 4 x RayNet network connections).

Links are provided on the left side of the page to all the router's configuration / settings pages.

## 6.4 Basic settings

### Wi-Fi connection page

The Wi-Fi connection page allows you to connect to a Wi-Fi access point such as the Wi-Fi provided by your marina. When connected to a Wi-Fi access point that has an internet connection your router will provide internet access to devices connected to the router's access point and devices connected to the router's wired RayNet network connections.

From the Wi-Fi connection page you can:

- Use the toggle switch to enable and disable the router's Wi-Fi connection.
- Select the info icon next to available Wi-Fi networks to view network details.
- Connect to an available Wi-Fi network.
- Connect to a Wi-Fi network manually.
- Forget a saved Wi-Fi network.

The router will connect automatically to saved Wi-Fi networks when they are in range. When available the Wi-Fi connection will be used in preference to a cellular connection.

### Mobile data & SIM management page

The mobile data & SIM management page provides access to settings related to the router's cellular connection, SIM management options and mobile data usage statistics. When a SIM card is inserted in to the router's SIM card slot the cellular connection will be enabled. If the SIM card has a valid connection and unused data allowance the router will provide internet access to devices connected to the router's access point and devices connected to the router's wired RayNet network connections. The router can be configured to use dual SIM cards.

When using dual SIM cards, you can enable automatic switching when one SIM card has no network coverage or when its data limit has been reached. Use the Tick box at the top of the page to enable SIM switching.

**Primary SIM:** — when using dual SIM cards, the Primary SIM option determines which SIM card the router will try to use first when it is powered up.

#### Note:

The primary SIM will be used if:

- Mobile data is enabled,
- The SIM has network coverage,
- The SIM has remaining data for the current period.

If the conditions above are not met then the router will switch to use the second SIM card.

From the mobile data & SIM management page you can select **SIM1** or **SIM2** to view the following details and settings for each SIM card.



- **Mobile data:** — switches mobile data on and off, when switched on the router can access the internet using your SIM card's data allowance.
- **Data roaming:** — switches data roaming on and off. Data roaming allows you to use your data allowance when outside of your home country. Using data roaming may incur additional fees from your network provider.
- **Data usage graph**— view data usage statistics.
- **Router data usage cycle** — set the date at which your data allowance renews each month.

- **Data warning and limit** — set data warning and limit so that you do not exceed your data allowance. You will be notified by the Raymarine app when the specified data warning and data limit for the month has been reached.
  - **Set data warning** — Enables and disables the data warning notification.
  - **Data warning** — Specifies the data warning notification value. The data warning should be set to a value under your data limit so that you receive a warning notification when you are running out of mobile data for the month (data usage cycle).
  - **Set data limit** — Enables and disables the data limit notification.
  - **Data limit** — Specifies the data limit notification value. The data limit should be set close to your monthly allowance so that you are notified when to stop using mobile data allowance for the selected SIM card.

**Note:** There may be differences between how the router and your network provider measure usage and so it is recommended that data limit is set lower than your actual data limit.

- **Mobile network** — The mobile network section provides details and settings for your SIM card network provider’s Access Point Name (APN). The APN settings are used to connect to your network provider and the internet.
  - **Network provider** — The name of your SIM card / network provider is displayed.
  - **SIM IMSI** — Your SIM card unique International Mobile Subscriber Identity number is displayed.
  - **Preferred network mode** — If required you can change your preferred network, the available options are: 3G/4G/Auto, 4G only or 3G only.
  - **Access Point Name** — A list of Access Point Names (APNs) applicable to your SIM provider will be displayed.

**Important:** If the APN you require is not listed or you’re unable to connect to the Internet using the current APN settings, you will need to modify an existing APN by selecting the “pencil” Edit icon on the right:

Name	APN	Username	
<input checked="" type="radio"/> Vodafone UK	internet	web	
<input type="radio"/> Vodafone UK Prepay	pp.vodafone.co.uk	wap	
<input type="radio"/> Custom APN	-	-	

**You will need to obtain the APN settings from the SIM card network provider.** You can usually find these settings by performing an Internet search; for example: “*Vodafone UK APN settings*”, or similar. If you are unable to find the settings on the Internet, you may need to **contact the network provider of the SIM card.**

- **Reset APN settings** — Reverts the APN settings to default values.
- **SIM info** — View SIM card details.
- **Lock SIM** — Lock the SIM card or change the PIN for the SIM card.

## Access point page

Wi-Fi enabled devices can connect to the router’s access point and connect to the internet using the router’s Wi-Fi network connection and / or cellular network connections.

The router’s access point can be enabled and disabled using the toggle switch at the top of the page.

When enabled the following router access point settings can be configured:

- **Access point name (SSID)** — This is the name of the network that you should connect your mobile devices to.
- **Password** — This is the password that needs to be entered when connecting your mobile device(s).
- **Preferred Wi-Fi channel** — Allows you to select your preferred Wi-Fi channel. Interference can occur in areas where many Wi-Fi networks are

using the same channel, moving to a less used channel should eliminate this interference.

- **Channel width** — Allows you to switch between single channel (20 MHz) 144 Mb and Dual channel (40 MHz) 300 Mb channel width. Dual channel provides faster speed, however in areas where there is wireless channel congestion a single channel may reduce interference.
- **Encryption type** — Allows selection of the type of encryption used, WPA2-PSA is the default and recommended encryption type.

**Note:** Changing the Encryption type to No encryption is not recommended as anyone within range will be able to connect to the router.

If you change any of the default settings then select **Save** at the top of the page to save the changes.

## Info page

The Info page provides technical information useful for diagnostics and troubleshooting.

From info page displays the following information:

- Router hardware related information.
- Router software related information.
- Cellular network related information.

A QR code is available at the bottom of the Info page that can be used to link your router to a Raymarine cloud account.

For troubleshooting purposes you can also save crash logs by selecting **Save system logs**.

## 6.5 Connected devices page

The connected devices page provides a list of all devices connected to the router using ethernet or wireless connections.

The details include:

- Device name
- MAC address

- IP address
- Connection type

## 6.6 Advanced settings

### LAN set-up

#### Ethernet configuration page

The ethernet configuration page provides IP address details and configuration settings for the router's wired network connections.

**Important:**

IP configuration is for advanced users and should not be changed, unless for a specific reason. Disabling automatic configuration will affect compatibility with Raymarine MFDs.

The **Configure IP** options are:

- **Automatically (DHCP on)** — This is the recommended setting which allows IP addresses to be automatically assigned to connected devices by the router using IP addresses within the range specified in the DHCP server.
- **Manually (DHCP on)** — This setting allows you to manually configure the router's LAN IP address, subnet mask and default gateway and allows connecting devices to be automatically assigned an IP address within the range you specify in the DHCP server.
- **Manually (DHCP off)** — This settings allows you to manually configure the router's LAN IP Address, subnet mask and default gateway but does not assign IP addresses to connected devices.

**Note:**

With DHCP switched off each wired device will have to be manually assigned an IP address in the same range as your router's IP address.

## Wi-Fi configuration page

The Wi-Fi configuration page provides IP address details and configuration settings for the router's Wi-Fi access point connection.

### Important:

IP configuration is for advanced users and should not be changed, unless for a specific reason.

The router's Wi-Fi IP address, subnet mask and default gateway can be configured and the IP address range and lease time used for the Wi-Fi DHCP server can be set.

## IPv6 page

IPv6 settings can be configured from the IPv6 page.

### Important:

IPv6 settings are for advanced users and should not be changed, unless for a specific reason.

You can change the router's IPv6 global ID and enable and disable IPv6 over ethernet and Wi-Fi connections using the relevant checkbox. You can also specify subnet IDs for both ethernet and Wi-Fi connections.

## GNSS page

The GNSS page provides settings and information for the router's internal GNSS receiver.

The following settings and information is available:

- **GNSS fix status** — provides position fix status.
- **Internal GNSS** — enables and disables the internal GNSS receiver.
- **Restart GNSS** — reboots the internal GNSS receiver.
- **GNSS Constellations** — enables use of a second GNSS constellation. Either GLONASS (Russian), Galileo (European) or Beidou (Chinese) GNSS can be used in addition to the GPS (US) constellation)
- **Differential positioning** — enables use of differential positioning satellites which enhances your position fix.
- **Differential positioning systems** — Allows selection of specific localized Satellite Based Augmentation Systems (SBAS).

- **Satellites in use** — Provides details of the positioning satellites currently being tracked.

## Inputs and outputs

Settings and status pages are available for the management of devices connected to the router's inputs & outputs connections.

The following pages are available

- **Channel monitoring and control** — view status of input channels and switch output channels on and off.
- **Channels configuration**— configure input and output channels.

## Input channel monitoring

The router's input channels (channels 1 to 4) can be monitored from the Channel monitoring & control page: **ADVANCED SETTINGS > Inputs & Outputs > Channel monitoring & control**.

- When an input channel's input type is set to **Analog voltage detect** the channel's voltage will be displayed.
- When the input channel's input type is set to **Digital voltage detect, normally open** or **Digital voltage detect, normally closed** then the channel's status i.e.: **ACTIVE** or **INACTIVE** will be displayed.

## Input channel configuration

The router's input channels (channels 1 to 4) can be configured from the Channels configuration page: **ADVANCED SETTINGS > Inputs & Outputs > Channels configuration**.

Selecting **Edit** will allow you to configure the **Channel name** and **Input type**.

The input type for Input channels can be configured as:

- **Analog voltage detect** — used for voltage monitoring.
- **Digital voltage detect, normally open** — used for switch state detection.
- **Digital voltage detect, normally closed** — used for switch state detection.

## Output channel control

The router's output channels (channels 5 to 8) can be controlled from the Channel monitoring & control page: **ADVANCED SETTINGS > Inputs & Outputs > Channel monitoring & control**.

Use the toggle switches to switch output channels on and off.



## Output channel configuration

The router's output channels (channels 5 to 8) can be configured from the Channels configuration page: **ADVANCED SETTINGS > Inputs & Outputs > Channels configuration**.

Selecting **Edit** will allow you to enable or disable the channel using the **Enable** checkbox. You can also customize the channel name using the **Channel name** field.

## Alert notifications page

Alert notifications can be configured for the router's supply voltage and input channel voltage.

### Note:

Each input channel warning must be configured with a unique Alert ID with a value between 1,000 and 65,000.

### Low voltage warning

A low voltage warning can be set which triggers when the voltage available to the router drops below a specified value.

By selecting **Edit** against the Low voltage warning you can specify a unique Alert ID, enable and disable notifications using the **Allow notification** checkbox and specify the voltage that will trigger the alert.

### Input channel alerts

Alerts can also be set for each input channel (Channels 1 to 4).

By selecting **Edit** against input channel you can specify a unique Alert ID, enable and disable notifications using the **Allow notification** checkbox.

When the input channel's input type has been configured as **Digital voltage detect, normally open** or **Digital voltage detect, normally closed** you can enter a voltage and select whether the alert is triggered when the channel has **Met** or **Not met** the specified voltage. You can also enter an alert notification message.

When the input channel's input type has been configured as **Analog voltage detect** you can enter a voltage and select whether the alert is triggered when the channel's voltage value is **below** or **above** the specified voltage. You can also enter an alert notification message.

## Power management page

The router includes power management options to help reduce power consumption whilst maintaining the ability to connect to the router remotely.

With **Always on** selected the router is fully powered.

With **Low power mode** selected the router is placed into a low power / sleep state. In Low power mode, Wi-Fi connections are disabled.

In low power mode the router can be woken by:

- a remote device connected to the Raymarine cloud service, via the Raymarine app.
- an alert notification, configured in the **Alert notifications** page.
- a Wake on LAN (WOL) signal from a device connected to the router's RayNet (SeaTalkhs®) network ports when LAN signal is selected under **Also wake on**.
- a device such as a switch, connected to one of the router's input channels, when the relevant input channel is selected under **Also wake on**.

### Note:

When power cycled, the router will also revert to **Always on** mode.

The input channels (Channels 1 to 4) can also be used to place the router into low power mode.

The router's output channels (Channels 5 to 8) can be used to wake connected devices or systems that have a wake-on-power input feature. Place a tick in the relevant output channel to wake the connected device when the router is woken from lower power mode.

### Important:

To keep changes made to the Power management options, click **Save**.

## Performing a router software upgrade

Raymarine® regularly issues software updates for its products which provide new and enhanced features and improved performance and usability. It is important to ensure that you have the latest software for your products by regularly checking the Raymarine® website for new software releases.

### Note:

The upgrade should be performed from a wired network device such as a personal computer or Raymarine MFD. It is not recommended to perform the upgrade process from a device connected using Wi-Fi.

To upgrade the software on your router follow the steps below:

1. Check your router's current software version (You can check what software version your router has by checking the Info page located under Basic settings of the router's web interface).
2. If available, Download updated software from the Raymarine website: [www.raymarine.com/software](http://www.raymarine.com/software).
3. Access the router's web interface:
  - From a Raymarine MFD refer to: [p.47 – Accessing the web interface from a Raymarine MFD](#)
  - From a personal computer refer to: [p.47 – Accessing the web interface using a wired connection](#)
4. Open the router's Software upgrade page located under Advanced settings.
5. If requested enter the router's admin password. and select OK.
6. Click Browse file to upload.
7. Locate and select the downloaded file.

*The file will upload to the router.*

8. Click Upgrade.

*The router will now be upgraded. The upgrade process can take some time, do NOT disconnect the device you are upgrading from until the process is complete.*

Once the process is complete the router will reboot.

## Restart & factory reset

If you encounter problems with your router it can be restarted or reset to its factory default settings from the Restart & factory reset page.

- Restart router — reboots the router.
- Reset to factory defaults — removes all changes made to the routers settings and resets it to the factory default settings.

**Note:** The router can also be reset to factory default settings using the reset button located on the front of the router. Refer to: [p.67 – Performing a hard reset](#)

## Performing a factory reset to restore default settings

Follow the steps below if you need to reset the router to its factory default settings, but want to re-connect it to the same Raymarine cloud account.

1. Access the router's web interface:
2. Select Restart & factory reset from the Advanced settings menu.
3. Select Reset to factory defaults.
4. Select Reset.

### Note:

If your router was linked to your Raymarine cloud account, then the next time you open your Raymarine app the router will be automatically added back to your account.

## Performing a factory reset prior to disposal / change of ownership or account

In the event that you need to dispose of your router or sell it, and your router has been linked to your Raymarine cloud account, it must first be removed from your account and then restored to its factory default settings.

### Note:

If your router is not connected to your Raymarine cloud account then steps 1 to 4 below are not necessary.

1. Open the Raymarine app on your mobile device and log in if required.
2. Select the menu icon located on the left of the screen to open the side menu.

3. If you have more than 1 boat system select the relevant boat system that the router is connected to.
4. Select the **YachtSense Link** router.
5. Select **Remove** and then confirm the removal.  
A confirmation e-mail will be sent to the e-mail address registered with your cloud account, and the router will no longer be linked to your account.
6. Access the router's web interface:
7. Select **Restart & factory reset** from the router's **Advanced settings** menu.
8. Select **Reset to factory defaults**.
9. Select **Reset**.

All personal details, passwords and cloud account details have now been removed, and the router has been reset to its factory default settings.

## Changing the admin password

The default password used to access the router's web interface can be changed.

### Important:

Ensure that you make a note of the new password. If you forget the new password you will not be able to log in to the router's web interface.

To change the password follow the steps below

1. Enter the current password in the **Current password:** field.
2. Enter your new password in the **Create new password:** field.
3. Re-enter the new password in the **Confirm new password:** field.
4. Click **Change password**.

### Note:

If you can no longer access the router's web interface you can perform a network settings reset. Refer to: [p.66 — Password reset \(forgotten password\)](#)

## 6.7 Help

Selecting the Help icon in the top right of the web interface will provide access to the router's help pages and online documentation for your router.

## 6.8 YachtSense Link router account transfer / ownership transfer

Yachtsense Link routers can only be linked to one account at a time.

To link the router to a different account it must first be removed from the existing account ("Offboarding"). For instructions refer to: [p.60 — Removing a router](#)

**Attempts to link to a router that is already linked to an account will fail.**

If you receive a message when trying to link to your router that states it is already assigned to another account, you will need to contact the previous owner and ask them to remove the router from their account.

If you cannot contact the previous owner, Raymarine technical support may be able to contact them on your behalf.

In most cases if the previous owner cannot be reached or is unwilling to remove the router from their account, it will NOT be possible for you to link your router.

If you purchased the router new, via either a third party reseller or as a refurbished unit, and you receive a message that your router is already assigned to an account, you should return it to the seller for a refund or exchange and let them know that it is already linked to another account.

## 6.9 Boat system and router removal (Offboarding)

### Removing a boat system

A boat system can be removed from the Raymarine app following the steps below:

1. Select the menu icon located on the left of the screen to open the side menu.
2. Select and hold on the boat system of the boat you want to remove.

*If you have more than one boat set up, you will first need to select the relevant boat system from the dropdown list.*

3. Select **Delete** and then confirm the deletion.
4. Select **OK**.
5. You must also unsync the MFD from the Raymarine app by accessing the **My data** menu on your MFD and selecting **Mobile sync** and **Cancel Raymarine app sync**.

The boat system and all of its devices are now removed from your app. If the deleted boat system included a YachtSense link router then the router will also be removed (offboarded) from your account and can now be linked (onboarded) again to the same account, or to a different account.

---

**Note:**

The router should be power cycled before attempting to link (onboard) it again.

## Removing a router

You can remove a YachtSense Link router from a boat system in the Raymarine app by following the steps below.

1. Select the menu icon located on the left of the screen to open the side menu.
2. If you have more than one boat system, select the relevant boat system that the router is connected to.
3. Select the **YachtSense Link** router.
4. Select **Remove** and then confirm the removal
5. You must also unsync the MFD from the Raymarine app by accessing the **My data** menu on your MFD and selecting **Mobile sync** and **Cancel Raymarine app sync**.

The router is now removed from the boat system and removed (offboarded) from your account. The router can now be linked (onboarded) again to the same account, or to a different account.

---

**Note:**

The router should be power cycled before attempting to link (onboard) it again.

# CHAPTER 7: TROUBLESHOOTING

## CHAPTER CONTENTS

- 7.1 Troubleshooting — page 62
- 7.2 LED diagnostics — page 62
- 7.3 Power up troubleshooting — page 63
- 7.4 Wi-Fi troubleshooting — page 64
- 7.5 Web interface access troubleshooting — page 65
- 7.6 Mobile / cellular data troubleshooting — page 65
- 7.7 Password reset (forgotten password) — page 66
- 7.8 Performing a network settings reset — page 67
- 7.9 Performing a hard reset — page 67

## 7.1 Troubleshooting

The troubleshooting information provides possible causes and the corrective action required for common problems that are associated with the installation and operation of your product.

Before packing and shipping, all Raymarine products are subjected to comprehensive testing and quality assurance programs. If you do experience problems with your product, this section will help you to diagnose and correct problems to restore normal operation.

If after referring to this section you are still having problems with your product, please refer to the Technical support section of this manual for useful links and Raymarine Product Support contact details.

## 7.2 LED diagnostics

The LEDs on the front of the router provide basic status information for the relevant network/connection.

### Cloud LED

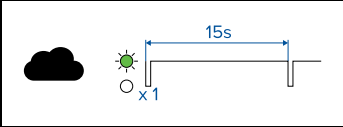
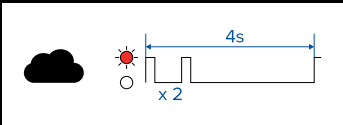
	(Green) Connected to cloud service.
	(Red) Connection error / server not found.

### 2G/3G/4G (Cellular / Diversity) LED

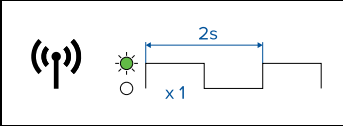
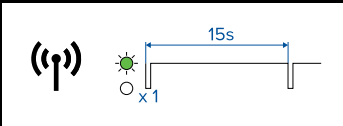
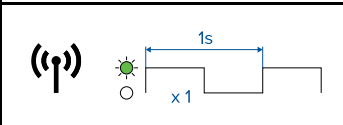

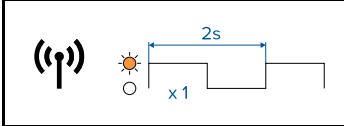
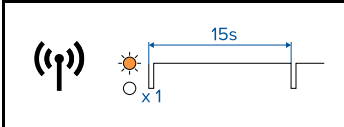
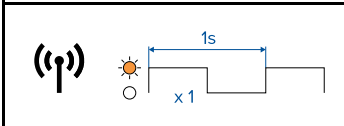
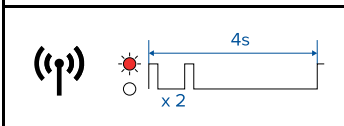
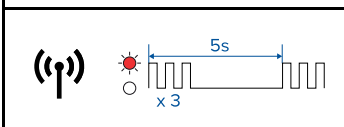
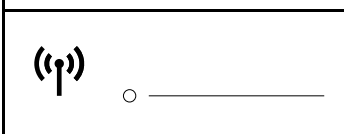

	(Green) Connecting to 4G.
	(Green) Connected to 4G.
	(Green) Connected to 4G and transmitting data.

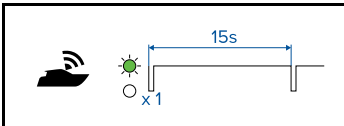
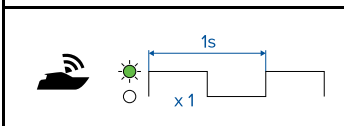
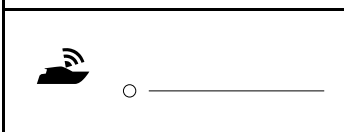
	(Amber) Connecting to 2G/3G.
	(Amber) Connected to 2G/3G.
	(Amber) Connected to 2G/3G and transmitting data.
	(Red) Not connected / no signal.
	(Red) No SIM card detected.
	(Off) Mobile data (Cellular) switched off.

### Boat Wi-Fi LED

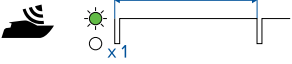
	(Green) Device(s) connected to router access point.
	(Green) Device(s) connected to router access point and transferring data.
	(Off) router access point switched off.

### Dock WLAN LED

 15s	(Green) Connected to Wi-Fi.
 1s	(Green) Connected to Wi-Fi and transferring data.
 4s	(Red) Unable to connect to Wi-Fi / No signal.
	(Off) Wi-Fi switched off.

### NMEA LED

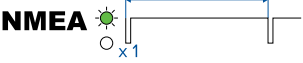
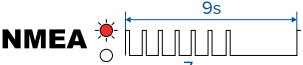
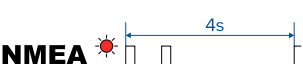

 15s	(Green) NMEA connected / OK.
 9s x 7	(Red) NMEA connected no data.
 4s x 2	(Red) NMEA not connected.

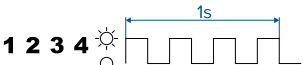
### SeaTalkhs network (1 / 2 / 3 / 4) LEDs

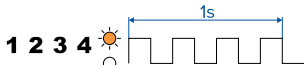
 1 2 3 4	(White) Port connected 1,000 Mbits/s.
 1s x 4	(White) Transferring data 1,000 Mbits/s.

 1 2 3 4	(Amber) Port connected 10/100 Mbits/s.
 1s x 4	(Amber) Transferring data 10/100 Mbits/s.

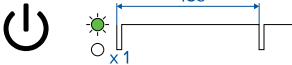
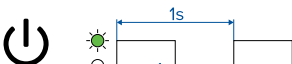
### Power LED

 15s	(Green) Powered up / Ok.
 1s x 1	(Green) GNSS (GPS) no fix / Initializing.
 1s x 1	(Amber) Software update in progress.
 3s x 1	(Red) Fault.

## 7.3 Power up troubleshooting

Before troubleshooting problems with your power connection, ensure that you have followed the power connection guidance provided in the product's installation instructions and performed a power cycle/reboot of the device. The troubleshooting information below can be used if you are experiencing problems with powering up your product.

#### Blown fuse / tripped breaker

1. Check the fuse, located inline with the power cable. Ensure that it has the correct rating (refer to *Connections* chapter), as an under-rated fuse can affect the power supplied to the product. If the fuse has blown, replace with a new fuse.

2. Check the condition of relevant / additional fuses and breakers and connections; replace if necessary.
3. If fuse keeps blowing, check for cable damage, broken connector pins or incorrect wiring.

#### Poor / damaged / insecure power supply cable / connections

1. Check that the power cable connector is fully inserted into the unit and locked in position.
2. Check the power supply cable and connectors for signs of damage or corrosion, replace if necessary.
3. With the unit turned on, try flexing the power cable near to the connector to see if this causes the unit to re-boot/lose power; replace if necessary.
4. Check the vessel's battery voltage, the condition of the battery terminals and power supply cables, ensuring connections are secure, clean and free from corrosion; replace if necessary.

#### Incorrect power connection

The power supply may be wired incorrectly, ensure the installation instructions have been followed.

#### Power source insufficient

Check that your power supply (battery or distribution panel) is providing a minimum of 10.8 V to each component in the system.

## 7.4 Wi-Fi troubleshooting

Before troubleshooting problems with your Wi-Fi connection, ensure that you have followed the Wi-Fi location requirements guidance provided in the relevant installation instructions and performed a power cycle/reboot of the devices you are experiencing problems with. The troubleshooting information below can be used if you are experiencing problems connecting your router to an external Wi-Fi network (Dock WLAN) such as the Wi-Fi provided at a marina or if you are experiencing problems connecting mobile devices to the router's Wi-Fi access point Boat Wi-Fi).

### **Cannot find network**

If you cannot find the Wi-Fi network, it could be for one of the following reasons:

- **Wi-Fi is disabled** — Enable the Wi-Fi connection on the device you are trying to connect to the network.

- **Router not broadcasting** — Ensure that the router you are trying to connect to is broadcasting its SSID. If you have no control over the router's settings or do not want the router to broadcast its SSID then you will need to connect to the router manually by entering its SSID and password.
- **Router is out of range** — Wi-Fi performance degrades over distance so devices farther away will receive less network bandwidth. Devices close to their maximum Wi-Fi range will experience slow connection speeds, signal dropouts or not being able to connect at all. Move the device closer to the router and try to connect.
- **Signal blocked or degraded** — Bulkheads, decks and other heavy structure can degrade and even block the Wi-Fi signal. Depending on the thickness and material used it may not always be possible to pass a Wi-Fi signal through certain structures. If possible, remove the obstruction, or try moving the device so that the obstruction is no longer present.

### **Cannot connect to the network**

If the network is available but you cannot connect to it check the following:

- **Incorrect network credentials** — Ensure you are entering the password correctly. Network passwords are case sensitive.
- **Wrong network** — Ensure you are selecting the correct network.
- **Router is out of range** — Wi-Fi performance degrades over distance so devices farther away will receive less network bandwidth. Devices close to their maximum Wi-Fi range will experience slow connection speeds, signal drop outs or not being able to connect at all. Move the device closer to the router and try to connect.
- **Signal blocked or degraded** — Bulkheads, decks and other heavy structure can degrade and even block the Wi-Fi signal. Depending on the thickness and material used it may not always be possible to pass a Wi-Fi signal through certain structures. If possible, remove the obstruction, or try moving the device so that the obstruction is no longer present.
- **Wi-Fi channel congestion** — In areas where there are a high number of Wi-Fi networks Wi-Fi channels can become congested making it difficult to connect or maintain a network connection. Try changing the Wi-Fi channel used by the router you are trying to connect to. You can use a free Wi-Fi analyzer app on a smart device to help you choose a less congested Wi-Fi channel.
- **Interference (2.4 GHz frequency)** — Interference can be caused by other devices that use the 2.4GHz frequency See list below of some common devices that use the 2.4GHz frequency:



- Bluetooth devices
- Microwave ovens
- Fluorescent lighting
- Cordless phones / baby monitors
- Motion sensors

Temporarily switch off devices in turn until you have identified the device causing the interference, then remove or reposition the offending device(s).

- **Interference (electrical and electronic devices)** — Interference caused by electrical and electronic devices or equipment and their associated cabling could generate an electromagnetic field which may interfere with the Wi-Fi signal. Temporarily switch off devices in turn until you have identified the device causing the interference, then remove or reposition the offending device(s).

### Slow connection / frequent connection dropouts

If you experience slow connection speeds or a connection that regularly drops out, work through the 'Cannot find network' and 'Cannot connect to the network' troubleshooting above.

## 7.5 Web interface access troubleshooting

Before troubleshooting problems with accessing the router's web interface, ensure that you have followed the relevant 'RayNet connection' details for wired devices or the 'Accessing the web interface' instructions provided in the router's installation and operation instructions and performed a power cycle/reboot of the router. The troubleshooting information below can be used if you are still experiencing problems accessing the web interface.

### Web interface not available

If you cannot access the router's web interface it could be for one of the following reasons:

#### No connection

Your device must have either a wired connection to one of the router's RayNet connections or be connected to the router's Wi-Fi access point to access the web interface.

### Unsupported browser

The web interface can be accessed using the following supported browsers: Chrome, Firefox, Edge and Safari. **Internet explorer (IE) is NOT supported.** If you experience problems using generic browsers on a mobile device try using one of the listed supported browsers instead.

### IP address

Your device's IP address must be in the same range as the router's IP address. By default most Wi-Fi and ethernet connections are configured to obtain an IP address automatically. This will ensure your device's and router's IP address are in the same range. If your device is assigned a static IP address then it must be in the same range as the router's IP address. Your router's IP address can be found on an MFD's Network settings tab: Homescreen > Settings > Network. Then select **Raymarine YachtSense Link** from the list of network devices, and select the Product Info option, alternatively you could use a network discovery tool to identify the router's IP address.

### VPN blocking access

Some VPNs can block access to the router's web interface. If you use a VPN ensure it is disconnected before trying to access the web interface.

### DNS not resolving

If for some reason your device cannot resolve the 'yachtsense.raymarine.com' address then try entering the routers IP address instead (e.g.: '198.18.0.239').

## 7.6 Mobile / cellular data troubleshooting

### No Internet connection

If you cannot access the Internet, and the Status for the Cloud and/or Mobile network connection is showing in the Raymarine mobile app or the Router Status page as Not in use, Not connected, or Error, it is most likely that the APN settings for your SIM card provider are incorrect:

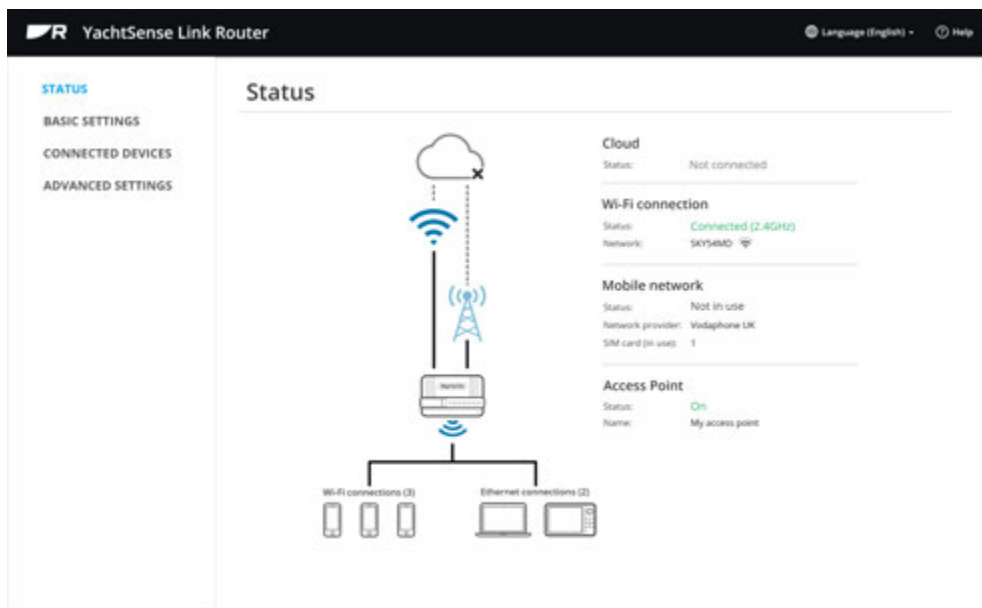

To resolve this, check your APN settings, by scrolling down to the bottom of the Router’s **Mobile data & SIM management** page:

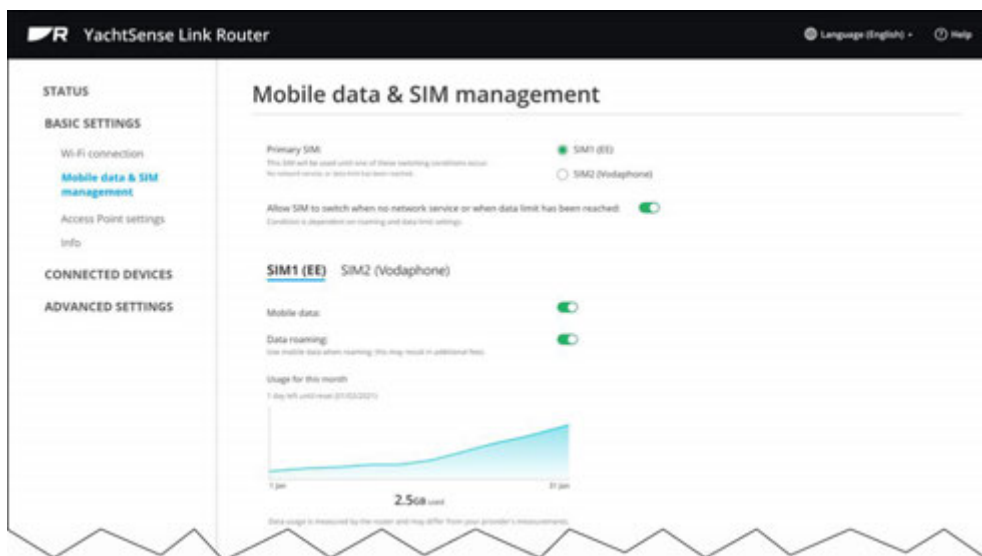

In the **Access Point Name** section of this page, a list of Access Point Names (APNs) applicable to your SIM provider will be displayed.

If the APN you require is not listed or you’re unable to connect to the Internet using the current APN settings, you will need to modify an existing APN by selecting the “pencil” Edit icon on the right:

Name	APN	Username	
<input checked="" type="radio"/> Vodafone UK	internet	web	
<input type="radio"/> Vodafone UK Prepay	pp.vodafone.co.uk	wap	
<input type="radio"/> Custom APN	-	-	

**You will need to obtain the APN settings from the SIM card network provider.** You can usually find these settings by performing an Internet search; for example: “*Vodafone UK APN settings*”, or similar. If you are unable to find the settings on the Internet, you may need to **contact the SIM card network provider.**

## 7.7 Password reset (forgotten password)

The default password that is required to access the router’s settings can be changed. It is important that when changing the password you make a note of it somewhere in case you forgot the password.

If the default password is changed and you have forgotten the new password you can perform a networking reset. Performing a networking reset will revert the router’s Wi-Fi and ethernet settings and the admin password to its default settings. The default password is printed on the credentials label located on the left side of the router.

## 7.8 Performing a network settings reset

If you have lost or can no longer remember the router's admin password you can perform a networking reset following the steps below.

### Note:

Performing a networking reset will revert all customized Wi-Fi and ethernet settings and the admin password to their factory default settings. All other settings will remain unchanged.

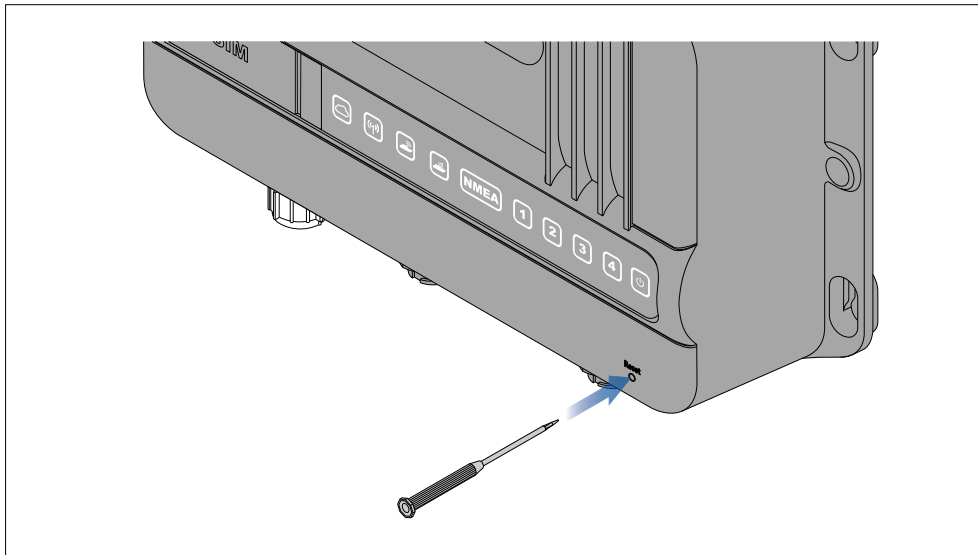

With the router powered on:

1. Insert a paper clip or a small screwdriver into the hard reset hole located on the bottom right of the router.
2. Press in and hold for approximately 2 seconds until the first 5 LEDs turn off and then blink green once simultaneously.
3. Remove the paperclip / screwdriver.

During the reset process the first 5 LEDs will turn solid amber. Once the Power LED turn solid green the networking reset is complete.

## 7.9 Performing a hard reset

If the router's web user interface becomes inaccessible then you can perform a hard reset of the router following the steps below.

### Note:

- Performing a factory reset will remove all customized settings and reset the router to its factory default settings.
- Before performing a hard reset try power cycling the router to see if that fixes the problem.

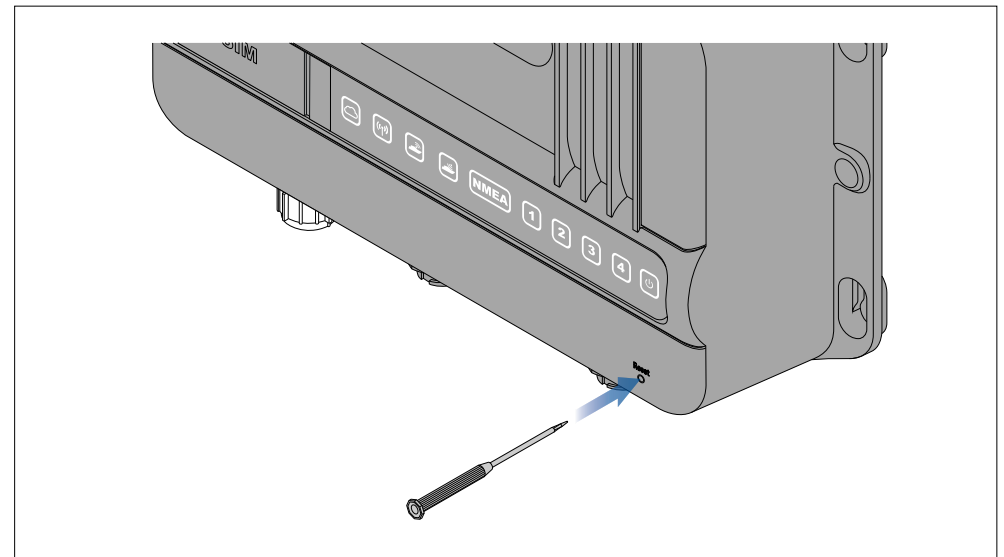

With the router powered on:

1. Insert a paper clip or a small screwdriver into the hard reset hole located on the bottom right of the router.
2. Press in and hold for approximately 7 seconds until the first 5 LEDs turn off and then blink green once simultaneously.
3. Remove the paperclip / screwdriver.

During the reset process the first 5 LEDs will turn solid amber. Once the Power LED turn solid green the router will be reset to its factory default settings and ready to use.

# CHAPTER 8: MAINTENANCE

## CHAPTER CONTENTS

- 8.1 Service and maintenance — page 69
- 8.2 Product cleaning — page 69
- 8.3 Product returns — page 69

## 8.1 Service and maintenance

This product contains no user serviceable components. Please refer all maintenance and repair to authorized Raymarine dealers. Unauthorized repair may affect your warranty.



### **Warning: High voltage**

This product contains high voltage. Adjustments require specialized service procedures and tools only available to qualified service technicians. There are no user serviceable parts or adjustments. The operator should never remove the cover or attempt to service the product.

## Routine equipment checks

It is recommended that you perform the following routine checks, on a regular basis, to ensure the correct and reliable operation of your equipment:

- Examine all cables for signs of damage or wear and tear.
- Check that all cables are securely connected.

## 8.2 Product cleaning

Best cleaning practices.

When cleaning products:

- Switch off power supply.
- Use a clean damp cloth to wipe clean.
- Do NOT use: abrasive, acidic, ammonia, solvent or other chemical based cleaning products.
- Do NOT use a jet wash.

## 8.3 Product returns

If you need to return your YachtSense Link router for service or repair you must remove it from your boat system first.

For instructions refer to: [6.9 Device removal](#)

# CHAPTER 9: TECHNICAL SUPPORT

## CHAPTER CONTENTS

- 9.1 Raymarine product support and servicing — page 71
- 9.2 Frequently Asked Questions (FAQs) — page 72
- 9.3 Learning resources — page 72
- 9.4 Product returns — page 72

## 9.1 Raymarine product support and servicing

Raymarine provides a comprehensive product support service, as well as warranty, service, and repairs. You can access these services through the Raymarine website, telephone, and e-mail.

### Product information

If you need to request service or support, please have the following information to hand:

- Product name.
- Product identity.
- Serial number.
- Software application version.
- System diagrams.

You can obtain this product information using diagnostic pages of the connected MFD.

### Servicing and warranty

Raymarine offers dedicated service departments for warranty, service, and repairs.

Don't forget to visit the Raymarine website to register your product for extended warranty benefits: <http://www.raymarine.co.uk/display?id=788>.

#### **United Kingdom (UK), EMEA, and Asia Pacific:**

- E-Mail: [emea.service@raymarine.com](mailto:emea.service@raymarine.com)
- Tel: +44 (0)1329 246 932

#### **United States (US):**

- E-Mail: [rm-usrepair@flir.com](mailto:rm-usrepair@flir.com)
- Tel: +1 (603) 324 7900

### Web support

Please visit the "Support" area of the Raymarine website for:

- **Manuals and Documents** — <http://www.raymarine.com/manuals>
- **Technical support forum** — <http://forum.raymarine.com>
- **Software updates** — <http://www.raymarine.com/software>

### Worldwide support

#### **United Kingdom (UK), EMEA, and Asia Pacific:**

- Help desk: <https://raymarine.custhelp.com/app/ask>

- Tel: +44 (0)1329 246 777

#### **United States (US):**

- Help desk: <https://raymarine.custhelp.com/app/ask>
- Tel: +1 (603) 324 7900 (Toll-free: +800 539 5539)

#### **Australia and New Zealand (Raymarine subsidiary):**

- E-Mail: [aus.support@raymarine.com](mailto:aus.support@raymarine.com)
- Tel: +61 2 8977 0300

#### **France (Raymarine subsidiary):**

- E-Mail: [support.fr@raymarine.com](mailto:support.fr@raymarine.com)
- Tel: +33 (0)1 46 49 72 30

#### **Germany (Raymarine subsidiary):**

- E-Mail: [support.de@raymarine.com](mailto:support.de@raymarine.com)
- Tel: +49 40 237 808 0

#### **Italy (Raymarine subsidiary):**

- E-Mail: [support.it@raymarine.com](mailto:support.it@raymarine.com)
- Tel: +39 02 9945 1001

#### **Spain (Authorized Raymarine distributor):**

- E-Mail: [sat@azimut.es](mailto:sat@azimut.es)
- Tel: +34 96 2965 102

#### **Netherlands (Raymarine subsidiary):**

- E-Mail: [support.nl@raymarine.com](mailto:support.nl@raymarine.com)
- Tel: +31 (0)26 3614 905

#### **Sweden (Raymarine subsidiary):**

- E-Mail: [support.se@raymarine.com](mailto:support.se@raymarine.com)
- Tel: +46 (0)317 633 670

#### **Finland (Raymarine subsidiary):**

- E-Mail: [support.fi@raymarine.com](mailto:support.fi@raymarine.com)
- Tel: +358 (0)207 619 937

#### **Norway (Raymarine subsidiary):**

- E-Mail: [support.no@raymarine.com](mailto:support.no@raymarine.com)
- Tel: +47 692 64 600

### Denmark (Raymarine subsidiary):

- E-Mail: [support.dk@raymarine.com](mailto:support.dk@raymarine.com)
- Tel: +45 437 164 64

### Russia (Authorized Raymarine distributor):

- E-Mail: [info@mikstmarine.ru](mailto:info@mikstmarine.ru)
- Tel: +7 495 788 0508

## 9.2 Frequently Asked Questions (FAQs)

A range of FAQs is available on the Raymarine website to assist you in using and troubleshooting your product.

To access the FAQs, visit the Raymarine website at the following link:

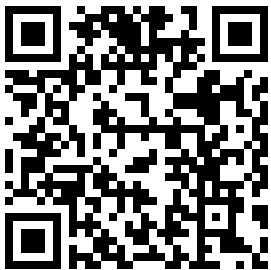

[https://raymarine.custhelp.com/app/answers/detail/a\\_id/5552](https://raymarine.custhelp.com/app/answers/detail/a_id/5552)

## 9.3 Learning resources

Raymarine has produced a range of learning resources to help you get the most out of your products.

### Video tutorials

Raymarine **official channel on YouTube:**

- [YouTube](#)

### Training courses

Raymarine regularly runs a range of in-depth training courses to help you make the most of your products. Visit the Training section of the Raymarine website for more information:

- <http://www.raymarine.co.uk/view/?id=2372>

### Technical support forum

You can use the Technical support forum to ask a technical question about a Raymarine product or to find out how other customers are using their Raymarine equipment. The resource is regularly updated with contributions from Raymarine customers and staff:

- <https://raymarine.custhelp.com/app/home>

## 9.4 Product returns

If you need to return your YachtSense Link router for service or repair you must remove it from your boat system first.

For instructions refer to: [6.9 Device removal](#)



# CHAPTER 10: TECHNICAL SPECIFICATION

## CHAPTER CONTENTS

- [10.1 YachtSense Link technical specification — page 74](#)

## 10.1 YachtSense Link technical specification

### Power specification

Nominal supply voltage:	12 / 24 V dc
Operating voltage range:	8 V dc to 32 V dc

### Environmental specification

Operating temperature range:	-25°C (-13°F) to + 55°C (131°F)
Storage temperature range:	-30°C (-22°F) to + 70°C (158°F)
Humidity:	up to 93% @ 40°C (104°F)
Water ingress protection:	IPx6 and IPx7

### Physical specification

Dimensions:	<ul style="list-style-type: none"> <li>• Width: 242.00 mm (9.53 in)</li> <li>• Height: 162.20 mm (6.39 in)</li> <li>• Depth: 63.00 mm (2.48 in)</li> </ul>
Weight:	1.03 Kg (2.26 lb)

## Wireless networks specification

BOAT Wi-Fi:	Wi-Fi access point mode frequencies: <ul style="list-style-type: none"> <li>• 2.4 GHz:(2412 MHz to 2472 MHz / 2422 MHz to 2462 MHz); 13.28 dBm</li> </ul>
DOCK WLAN:	Wi-Fi station mode frequencies: <ul style="list-style-type: none"> <li>• 2.4 GHz:(2412 MHz to 2472 MHz / 2422 MHz to 2462 MHz); 14.79 dBm</li> <li>• 5 GHz (5150 MHz to 5350 MHz / 5470 MHz to 5725 MHz); 14.94 dBm</li> <li>• 5.8 GHz (5725 MHz to 5875 MHz); 13.74 dBm</li> </ul>
Cellular / Diversity:	2G/3G/4G frequencies: <ul style="list-style-type: none"> <li>• LTE-FDD: B1/B2/B3/B4/B5/B7/B8 /B12/B13/B18/B19/B20/B25/B26/B28</li> <li>• LTE-TDD: B38/B39/B40/B41</li> <li>• WCDMA: B1/B2/B4/B5/B6/B8/B19</li> <li>• GSM: B2/B3/B5/B8</li> </ul>
LTE category:	4
Maximum download speed:	*150 Mbps
Maximum upload speed:	*50 Mbps

\*Actual performance will vary and usually be less than the stated maximums.

# CHAPTER 11: SPARES AND ACCESSORIES

## CHAPTER CONTENTS

- 11.1 Spares and Accessories — page 76
- 11.2 RayNet to RayNet cables and connectors — page 77
- 11.3 RayNet to RJ45 adapter cables — page 78
- 11.4 SeaTalkng<sup>®</sup> cables and accessories — page 80

## 11.1 Spares and Accessories

### Accessories

- R70800 — YachtSense Link I/O cable kit.
- A80701 — 5-in-1 antenna extension cable 5 m (16.4 ft).
- A70718 — 5-in-1 antenna thread extender kit.

### Spares

- R70835 — YachtSense Link router only.
- R70836 — Replacement Wi-Fi antenna pair.
- R70799 — YachtSense Link power cable 1.5 m (4.9 ft) with 8 A fitted fuse.
- R70837 — replacement 5-in-1 antenna.
- R70870 — 5-in-1 antenna replacement gasket and nut.
- A62360 — RayNet to RJ45 cable 1 m (3.3 ft).

## 11.2 RayNet to RayNet cables and connectors

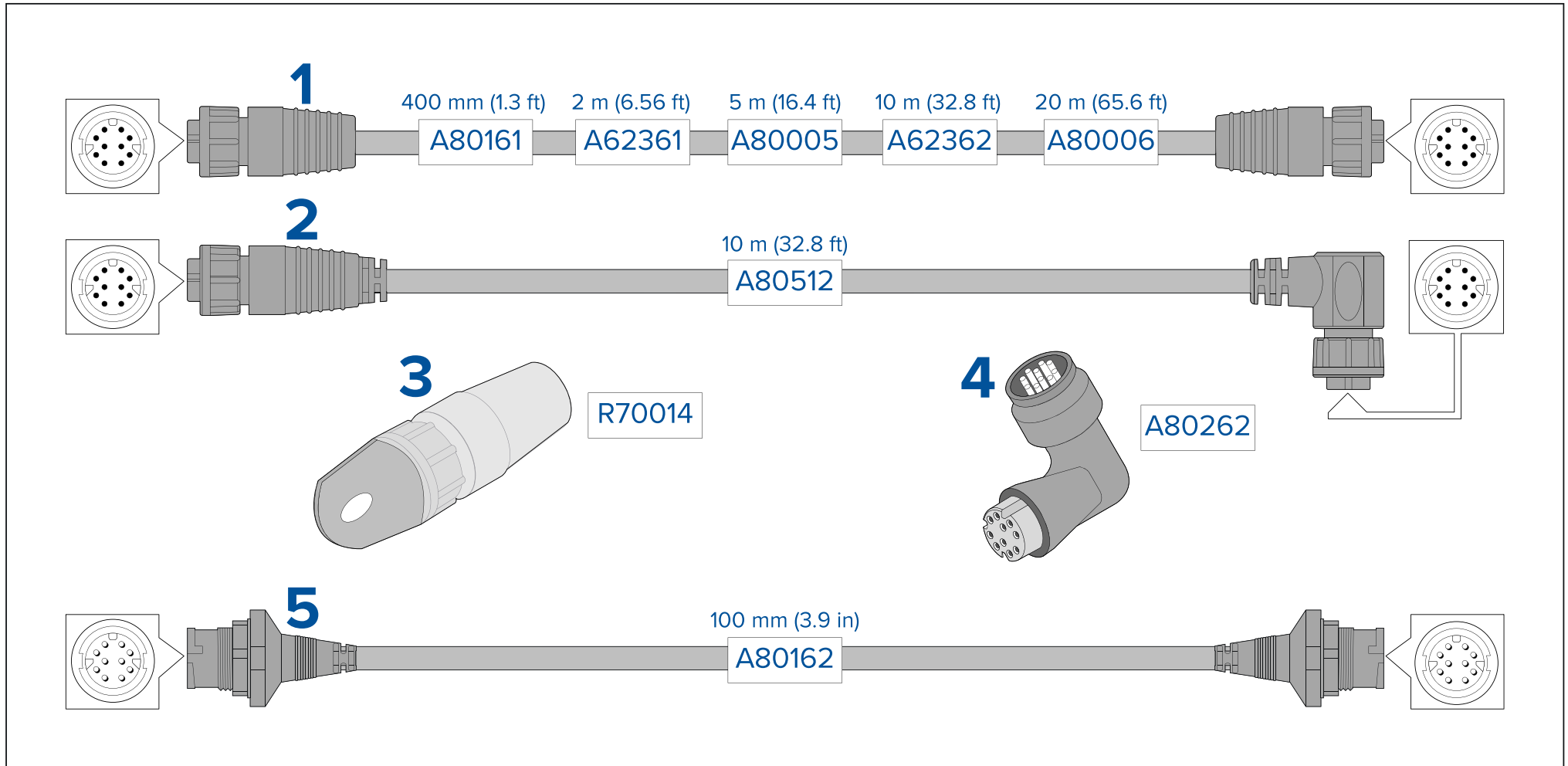

1. Standard RayNet connection cable with a RayNet (female) socket on both ends.
2. Right-angle RayNet connection cable with a straight RayNet (female) socket on one end, and a right-angle RayNet (female) socket on the other end. Suitable for connecting at 90° (right angle) to a device, for installations where space is limited.
3. RayNet cable puller (5 pack).
4. RayNet to RayNet right-angle coupler / adaptor. Suitable for connecting RayNet cables at 90° (right angle) to devices, for installations where space is limited.
5. Adapter cable with a RayNet (male) plug on both ends. Suitable for joining (female) RayNet cables together for longer cable runs.

## 11.3 RayNet to RJ45 adapter cables

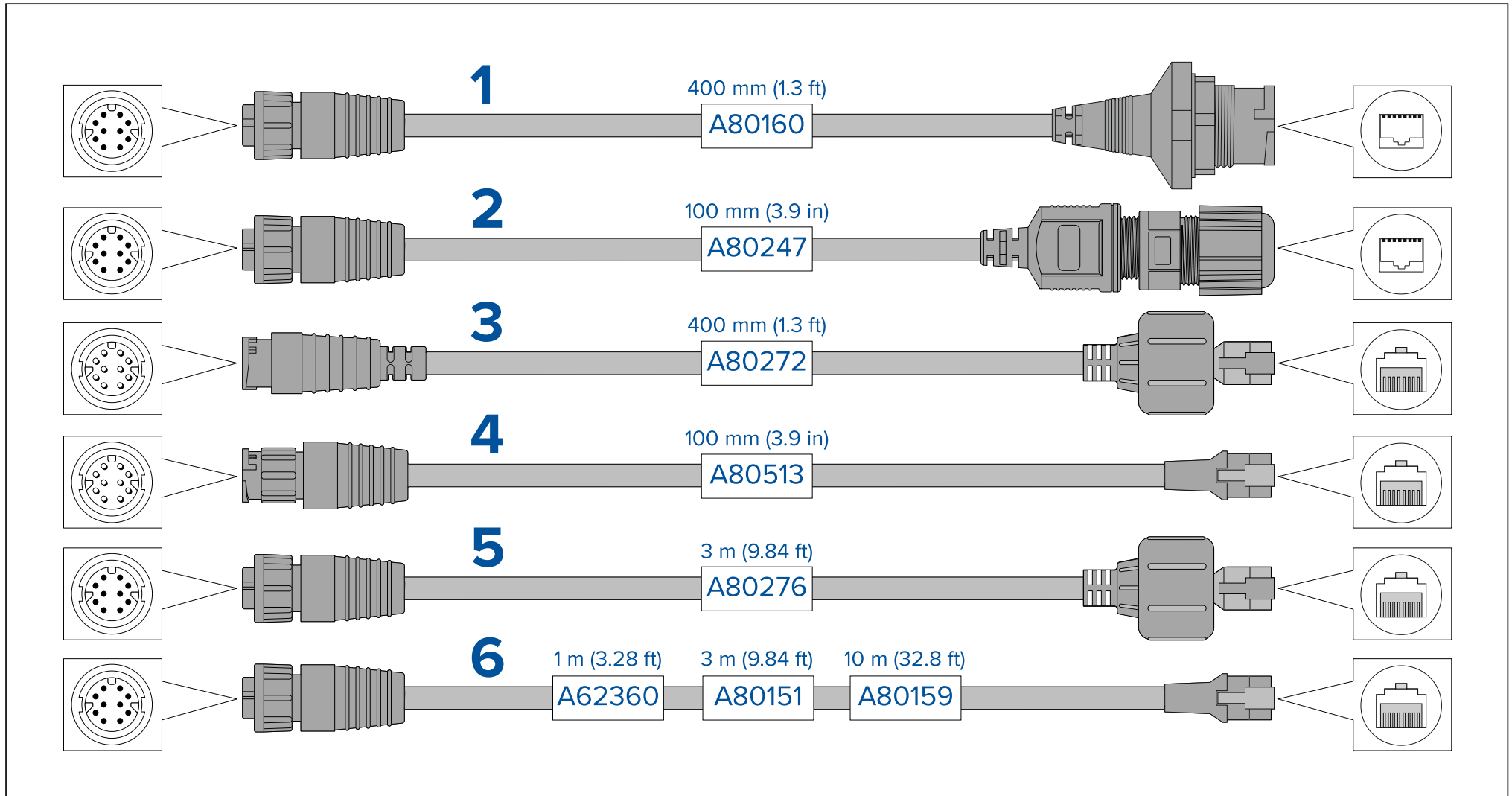

1. Adapter cable with a RayNet (female) socket on one end, and a waterproof (female) socket on the other end accepting the following cables with an RJ45 SeaTalkhs<sup>®</sup> waterproof locking (male) plug:

- A62245 (1.5 m).
- A62246 (15 m).

2. Adapter cable with a RayNet (female) socket on one end, and a waterproof (female) RJ45 socket on the other end, along with a locking gland for a watertight fit.
3. Adapter cable with a RayNet (male) plug on one end, and an RJ45 SeaTalkhs<sup>®</sup> waterproof (male) plug on the other end.
4. Adapter cable with a RayNet (male) plug on one end, and an RJ45 SeaTalkhs<sup>®</sup> (male) plug on the other end.
5. Adapter cable with a RayNet (female) socket on one end, and an RJ45 SeaTalkhs<sup>®</sup> waterproof (male) plug on the other end.
6. Adapter cable with a RayNet (female) socket on one end, and an RJ45 SeaTalkhs<sup>®</sup> (male) socket on the other end.

## 11.4 SeaTalkng<sup>®</sup> cables and accessories

SeaTalkng<sup>®</sup> cables and accessories for use with compatible products.

### SeaTalkng<sup>®</sup> kits

SeaTalkng kits enable you to create a simple SeaTalkng backbone.

**Starter kit (T70134)** consists of:

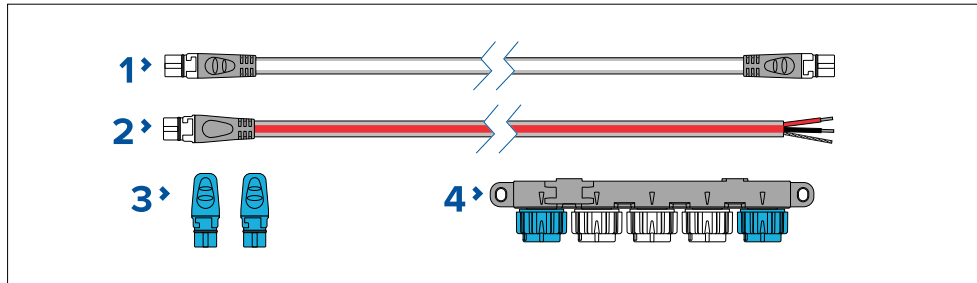

- 1 x 3 m (9.8 ft) Spur cable (A06040). Used to connect device to the SeaTalkng backbone.
- 1 x 2 m (6.6 ft) Power cable (A06049). Used to provide 12 V dc power to the SeaTalkng backbone.
- 2 x Backbone terminators (A06031). Terminators must be fitted to both ends of the SeaTalkng backbone.
- 1 x 5-Way connector (A06064). Each connector block allows connection of up to 3 SeaTalkng devices. Multiple connector blocks can be 'daisy chained' together.

**Backbone kit (A25062)** consists of:

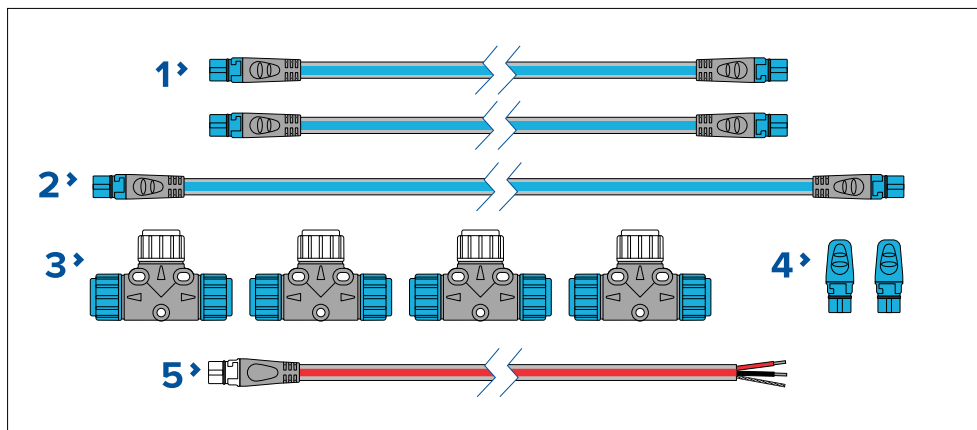

- 2 x 5 m (16.4 ft) Backbone cables (A06036). Used to create and extend the SeaTalkng backbone.
- 1 x 20 m (65.6 ft) Backbone cable (A06037). Used to create and extend the SeaTalkng backbone.
- 4 x T-piece (A06028). Each T-piece allows connection of one SeaTalkng device. Multiple T-pieces can be 'daisy chained' together.
- 2 x Backbone terminators (A06031). Terminators must be fitted to both ends of the SeaTalkng backbone.
- 1 x 2 m (6.6 ft) Power cable (A06049). Used to provide 12 V dc power to the SeaTalkng backbone.

**Evolution autopilot cable kit (R70160)** consists of:

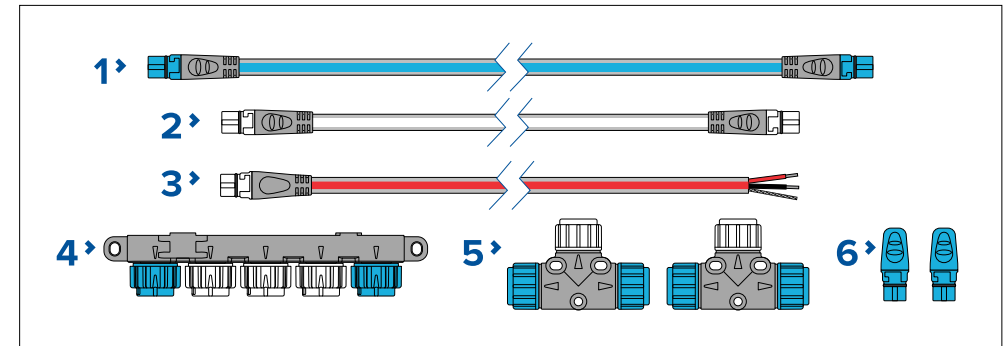

- 1 x 5 m (16.4 ft) Backbone cable (A06036). Used to create and extend the SeaTalkng backbone.
- 1 x 1 m (3.3 ft) Spur cable (A06040). Used to connect device to the SeaTalkng backbone.
- 1 x 2 m (6.6 ft) Power cable (A06049). Used to provide 12 V dc power to the SeaTalkng backbone.
- 1 x 5-Way connector (A06064). Each connector block allows connection of up to 3 SeaTalkng devices. Multiple connector blocks can be 'daisy chained' together.
- 2 x T-pieces (A06028). Each T-piece allows connection of one SeaTalkng device. Multiple T-pieces can be 'daisy chained' together.
- 2 x Backbone terminators (A06031). Terminators must be fitted to both ends of the SeaTalkng backbone.

**SeaTalk to SeaTalkng converter kit (E22158)** consists of:



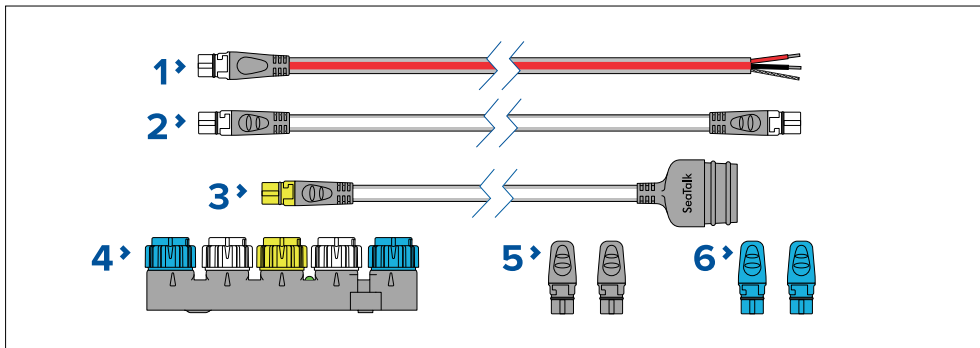

1. 1 x 2 m (6.6 ft) Power cable (A06049). Used to provide 12 V dc power to the SeaTalkng backbone.
2. 1 x 1 m (3.3 ft) Spur cable (A06039). Used to connect a device to the SeaTalkng backbone.
3. 1 x 0.4 m (1.3 ft) SeaTalk (3 pin) to SeaTalkng adapter cable (A22164). Used to connect SeaTalk devices to the SeaTalkng backbone via the SeaTalk to SeaTalkng converter.
4. 1 x SeaTalk to SeaTalkng converter (E22158). Each converter allows connection of one SeaTalk device and up to 2 SeaTalkng devices.
5. 2 x Spur blanking plugs (A06032). Used to cover unused spur connections in 5-way blocks, T-piece connectors and SeaTalk to SeaTalkng converter.
6. 2 x Backbone terminators (A06031). Terminators must be fitted to both ends of the SeaTalkng backbone.

**NMEA 0183 VHF 2 wire to SeaTalkng converter kit (E70196)** consists of:

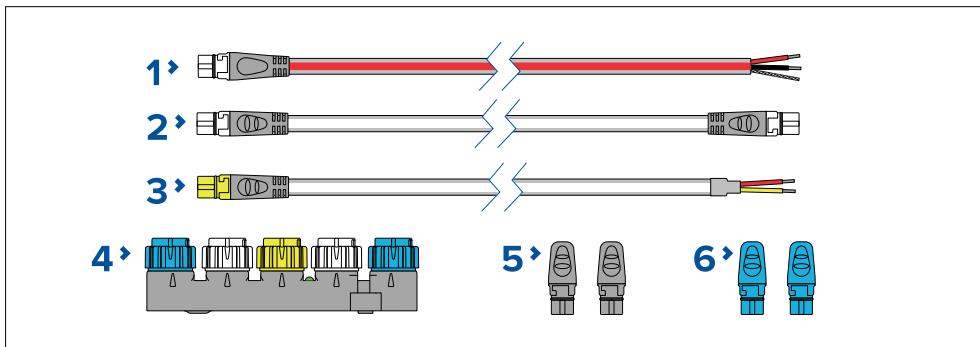

1. 1 x 2 m (6.6 ft) Power cable (A06049). Used to provide 12 V dc power to the SeaTalkng backbone.

2. 1 x 1 m (3.3 ft) Spur cable (A06039). Used to connect a device to the SeaTalkng backbone.
3. 1 x 1 m (3.3 ft) NMEA 0183 VHF stripped-end (2 wire) to SeaTalkng adapter cable (A06071). Used to connect an NMEA 0183 VHF radio to the SeaTalkng backbone via the NMEA 0183 VHF to SeaTalkng converter.
4. 1 x SeaTalk to SeaTalkng converter (E22158). Each converter allows connection of 1 SeaTalk device and up to 2 SeaTalkng devices.
5. 2 x Spur blanking plugs (A06032). Used to cover unused spur connections in 5-way blocks, T-piece connectors and SeaTalk to SeaTalkng converter.
6. 2 x Backbone terminators (A06031). Terminators must be fitted to both ends of the SeaTalkng backbone.

### SeaTalkng<sup>®</sup> spur cables

SeaTalkng spur cables are required to connect devices to the SeaTalkng backbone.

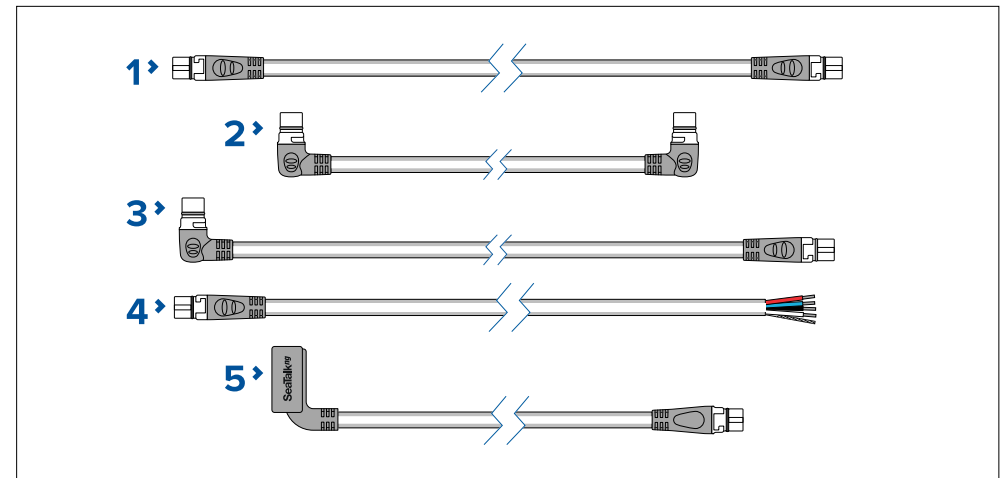

1. SeaTalkng spur cables:
  - 0.4 m (1.3 ft) Spur cable (A06038).
  - 1 m (3.3 ft) Spur cable (A06039).
  - 3 m (9.8 ft) Spur cable (A06040).
  - 5 m (16.4 ft) Spur cable (A06041).
2. 0.4 m (1.3 ft) Elbow (right angled) to elbow spur cable (A06042). Used in confined spaces where a straight spur cable will not fit.

3. 1 m (3.3 ft) Elbow (right angled) to straight spur cable (A06081). Used in confined spaces where a straight spur cable will not fit.
4. SeaTalkng to stripped-end spur cables (Connects compatible product that do not have a SeaTalkng connector such as transducer pods):
  - 1 m (3.3 ft) SeaTalkng to stripped-end spur cable — A06043
  - 3 m (9.8 ft) SeaTalkng to stripped-end spur cable — A06044
5. 0.3 m (1.0 ft) ACU / SPX autopilot to SeaTalkng spur cable (R12112). Connects the course computer to the SeaTalkng backbone. This connection can also be used to provide 12 V dc power to the SeaTalkng backbone.

### SeaTalkng® backbone cables

SeaTalkng backbone cables are used to create or extend a SeaTalkng backbone.

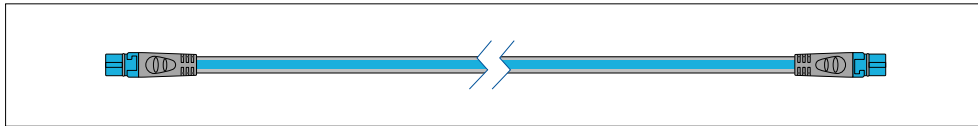

- 0.4 m (1.3 ft) Backbone cable (A06033).
- 1 m (3.3 ft) Backbone cable (A06034).
- 3 m (9.8 ft) Backbone cable (A06035).
- 5 m (16.4 ft) Backbone cable (A06036).
- 9 m (29.5 ft) Backbone cable (A06068).
- 20 m (65.6 ft) Backbone cable (A06037).

### SeaTalkng® power cables

SeaTalkng power cables are used to provide the SeaTalkng backbone with a single 12 V dc power source. The power connection must include a 5 amp inline fuse (not supplied).

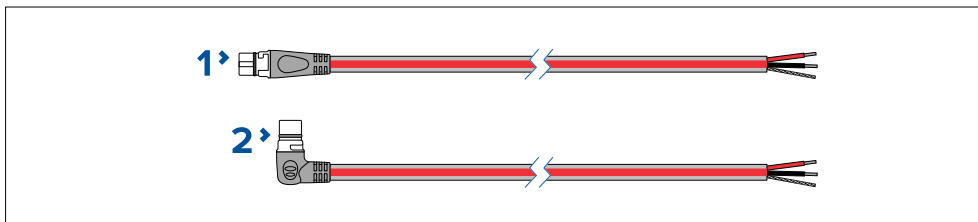

1. 2 m (6.6 ft) Power cable (straight) (A06049).

2. 2 m (6.6 ft) Elbow (right angled) power cable (A06070).

### SeaTalkng® connectors

SeaTalkng connectors are used to connect SeaTalkng devices to the SeaTalkng backbone and to create and extend the backbone.

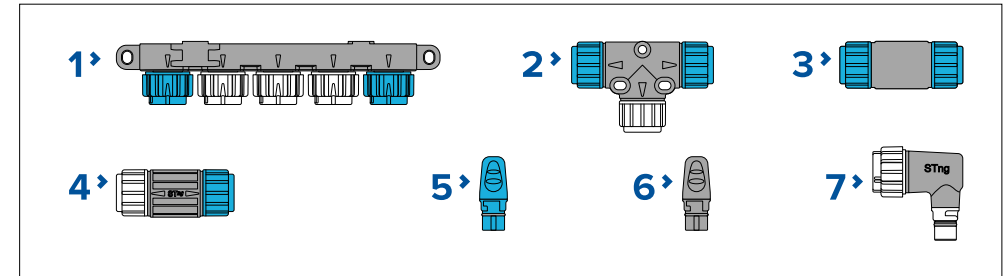

1. 5-Way connector (A06064). Each connector block allows connection of up to 3 SeaTalkng devices. Multiple connector blocks can be 'daisy chained' together.
2. T-piece (A06028). Each T-piece allows connection of one SeaTalkng device. Multiple T-pieces can be 'daisy chained' together.
3. Backbone extender (A06030). Used to connect 2 backbone cables together.
4. Inline terminator (A80001). Used to connect a spur cable and SeaTalkng device at the end of a backbone instead of a backbone terminator.
5. Backbone terminator (A06031). Terminators must be fitted to both ends of the SeaTalkng backbone.
6. Spur blanking plugs (A06032). Used to cover unused spur connections in 5-way blocks, T-piece connectors, or the SeaTalk to SeaTalkng converter.
7. Spur connector right angled elbow (A06077). Used in confined spaces where a straight spur cable will not fit.

### SeaTalkng® adaptors and adaptor cables

SeaTalkng adaptor cables are used to connect devices designed for different CAN bus backbones (e.g.: SeaTalk or DeviceNet) to the SeaTalkng backbone.

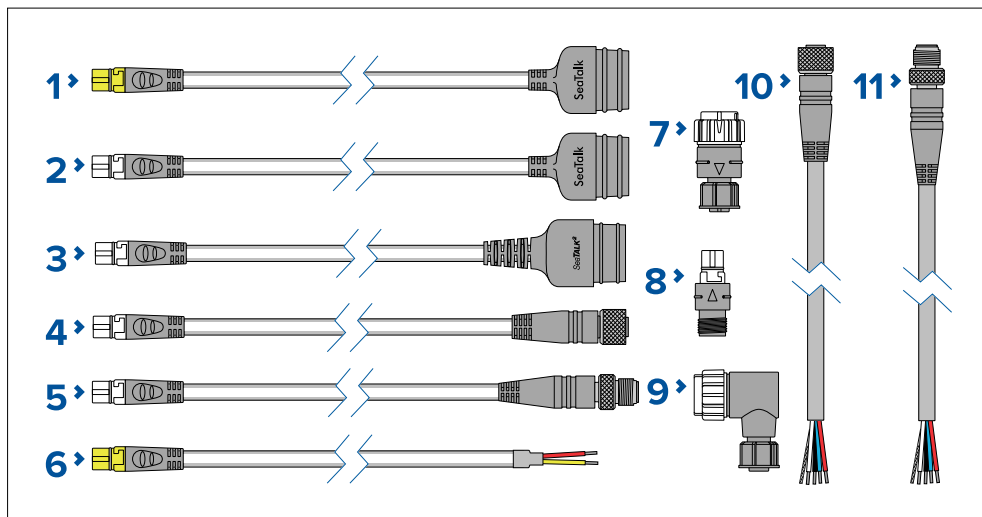

1. 1 m (3.3 ft) SeaTalk (3 pin) to SeaTalkng converter cable (A22164 / A06073). Can be used to connect a SeaTalk device to a SeaTalkng backbone via the SeaTalk to SeaTalkng converter, or to connect a SeaTalkng product directly to a SeaTalk network.
2. 0.4 m (1.3 ft) SeaTalk (3 pin) to SeaTalkng adaptor cable (A06047). Can be used to connect a SeaTalk device to a SeaTalkng backbone via the SeaTalk to SeaTalkng converter, or to connect a SeaTalkng product directly to a SeaTalk network.
3. 0.4 m (1.3 ft) SeaTalk2 (5 pin) to SeaTalkng adaptor cable (A06048). Used to connect SeaTalk2 devices or networks to a SeaTalkng backbone.
4. SeaTalkng to DeviceNet (female) adaptor cables connect NMEA 2000 devices that use a DeviceNet connector to the SeaTalkng backbone, or connects SeaTalkng devices to an NMEA 2000 network. The following cables are available:
  - 0.4 m (1.3 ft) SeaTalkng to DeviceNet (female) adaptor cable (A06045).
  - 1 m (3.3 ft) SeaTalkng to DeviceNet (female) adaptor cable (A06075).
5. SeaTalkng to DeviceNet (male) adaptor cables. Connect NMEA 2000 devices that use a DeviceNet connector to the SeaTalkng backbone, or connect SeaTalkng devices to an NMEA 2000 network. The following cables are available:
  - 0.1 m (0.33 ft) SeaTalkng to DeviceNet (male) adaptor cable (A06078).
  - 0.4 m (1.3 ft) SeaTalkng to DeviceNet (male) adaptor cable (A06074).

- 1 m (3.3 ft) SeaTalkng to DeviceNet (male) adaptor cable (A06076).
  - 1.5 m (4.92 ft) SeaTalkng to DeviceNet (male) adaptor cable (A06046).
6. 1 m (3.3 ft) NMEA 0183 VHF stripped-end (2 wire) to SeaTalkng adapter cable (A06071). Used to connect an NMEA 0183 VHF radio to the SeaTalkng backbone via the NMEA 0183 VHF to SeaTalkng converter.
  7. SeaTalkng (male) to DeviceNet (female) adaptor (A06082).
  8. SeaTalkng (female) to DeviceNet (male) adaptor (A06083).
  9. SeaTalkng (male) to DeviceNet (female) elbow (right angled) adaptor (A06084).
  10. (0.4 m (1.3 ft) DeviceNet (female) to stripped-end adaptor cable (E05026).
  11. (0.4 m (1.3 ft) DeviceNet (male) to stripped-end adaptor cable (E05027).



## Appendix A NMEA 2000 PGN support

### Administration PGNs

- **59392** — ISO Acknowledge (Receive / Transmit)
- **59904** — ISO Request (Receive / Transmit)
- **60160** — ISO Transport protocol, data transfer (Receive)
- **60416** — ISO Transport protocol, connection management — BAM group function (Receive)
- **60928** — Address claim (Receive / Transmit)
- **65240** — ISO Commanded address (Receive)
- **126208** — Request group message (Receive)
- **126208** — Command group message (Receive)
- **126208** — Acknowledge group message (Transmit)
- **126464** — PGN transmit and receive list (Transmit)
- **126993** — Heartbeat (Transmit)
- **126996** — Product information (Transmit)
- **126998** — Configuration information (Transmit)

### Data PGNs

- **126983** — Alert (Transmit)
- **126985** — Alert configuration (Transmit)
- **126986** — Alert configuration (Transmit)
- **126992** — System time (Transmit)
- **127250** — Vessel heading (Receive)
- **127251** — Rate of Turn (Receive)
- **127257** — Attitude (Receive)
- **127488** — Engine parameters, rapid update (Receive)
- **127489** — Engine parameters, dynamic (Receive)
- **127493** — Transmission parameters, dynamic (Receive)
- **127496** — Trip fuel consumption, vessel (Receive)
- **127497** — Trip fuel consumption, engine (Receive)

- **127498** — Engine parameters, static (Receive)
- **127501** — Binary status report (Receive)
- **127502** — Switch bank control (Receive/Transmit)
- **127503** — AC input status DEPRECATED (Receive)
- **127504** — AC output status DEPRECATED (Receive)
- **127505** — Fluid level (Receive)
- **127506** — DC detailed status (Receive)
- **127507** — Charger status DEPRECATED (Receive)
- **127508** — Battery status (Receive)
- **127509** — Inverter status DEPRECATED (Receive)
- **128259** — Speed (Receive)
- **128267** — Water depth (Receive)
- **129025** — Position, rapid update (Transmit)
- **129026** — COG & SOG, rapid update (Receive/Transmit)
- **129029** — GNSS position data (Receive/Transmit)
- **129033** — Local time offset (Receive/Transmit)
- **129044** — Datum (Transmit)
- **129539** — GNSS DOPs (Transmit)
- **129540** — GNSS Sats in view (Transmit)
- **129542** — GNSS Pseudorange noise statistics (Transmit)
- **129547** — GNSS Pseudorange error statistics (Transmit)
- **130306** — Wind data (Receive)
- **130310** — Environmental parameters DEPRECATED (Receive)
- **130311** — Environmental parameters DEPRECATED (Receive)
- **130312** — Temperature DEPRECATED (Receive)
- **130313** — Humidity (Receive)
- **130314** — Actual pressure (Receive)
- **130576** — Trim ab status (Receive)

## Appendix B Document change history

Document revision	Changes
81397 (Rev 5) Date: 06–2022	<ul style="list-style-type: none"><li>• Updated to reflect new 5 wire input cable.</li><li>• Updated input channel connection details.</li><li>• Updated output channel connection details.</li><li>• Added Raymarine app linking details.</li><li>• Added router transfer of ownership details.</li><li>• Added Raymarine app device removal details.</li><li>• Updated input channel monitoring and configuration details using the web interface.</li><li>• Updated alert notification details.</li><li>• Updated details for accessing web interface via the LightHouse 4 homescreen.</li><li>• Added details for third party hardware connections.</li><li>• Added YachtSense ecosystem chapter.</li></ul>
81397 (Rev 4) Date: 02–2022	Initial public release







# Index

## A

Access point	
Settings	54
Status	53
Access Point Name (APN)	54, 66
Edit	54, 66
Accessories	76
Network adapter cables	78
Network cables	77
RayNet cables	77
SeaTalkng adaptor cables	82
SeaTalkng backbone cables	82
SeaTalkng cables	80
SeaTalkng connectors	82
SeaTalkng kits	80
SeaTalkng Power cables	82
SeaTalkng spur cables	81
Account setup	52
Account transfer	11, 23, 59
Always on	57
Antenna extension cable	41
APN settings	50

## B

Beidou	56
Boat Wi-Fi connection LED diagnostics	62

## C

Cable	
Protection	34
Strain relief	34
Cable routing	26
Cellular LED diagnostics	62
Cleaning	69
Cloud	
Status	53
Cloud LED diagnostics	62

Compass safe distance	27
Connected devices	55
Connecting cables	34
Connections	14, 34
5-in-1 antenna	40
5-in-1 antenna extension	41
Battery	38
Boat Wi-Fi antenna	41
Cellular	40–41
Digital input	44
Distribution panel	37
Diversity	40–41
Dock WLAN	40–41
General cabling guidance	34
GNSS (GPS)	40–41
Grounding	39
Input channels	43
MFD	17, 36
Output channels	44
Overview	35
Power supply	36
RayNet	42
SeaTalkng	42
Voltage monitor	44
Wi-Fi	41
YachtSense Digital Control System	17, 36
YachtSense Link	35
Contact details	71

## D

Data limit	54
Data roaming	53
Data usage	53
Data usage cycle	53
Data warning	54
Data warning and limit	54
Declaration of Conformity	10
DHCP	55
Diagnostics LEDs	62
Differential positioning	56
Dimensions	

5-in-1 antenna .....	29
YachtSense Link .....	28
Dock WLAN LED.....	63
Documentation	
Installation instructions .....	13
Mounting template.....	13
Operation instructions .....	13

## E

Electromagnetic Compatibility.....	27
EMC, See Electromagnetic Compatibility	

## F

Forgotten password .....	66
Frequently Asked Questions (FAQs) .....	72
Fuse rating.....	37

## G

GLONASS .....	56
GNSS.....	56
GPS.....	56

## H

Help page.....	59
----------------	----

## I

Inputs & Outputs.....	56
Installation	
Best practice .....	39
surface requirements.....	26
Interference	
Compass .....	27
Electrical .....	26
RF.....	27
IPv6 settings .....	56

## L

Link router .....	52
Location requirements	
5-in-1 antenna .....	28
Wireless .....	25–26
Wireless interference.....	26
YachtSense™ Link .....	25
Lock SIM.....	54
Low power mode.....	57

## M

Maintenance.....	69
Micro SIM.....	29
Mobile data.....	53
Mobile network	
Status.....	53
Mounting	
5-in-1 antenna .....	32
YachtSense Link .....	31

## N

Nano SIM.....	29
Network diagnostics.....	63
Network status .....	62
Network Status .....	63
NMEA 2000.....	85
NMEA 2000 LED diagnostics .....	63

## O

Offboarding .....	11, 22–23, 59–60
Onboarding .....	52

## P

Parts supplied.....	14
Password reset.....	66
PGNs .....	85
Power	
Battery connection.....	38

Distribution .....	37
Distribution panel.....	37
Grounding.....	39
Sharing a breaker .....	37
Power cable extension .....	39
Power LED diagnostics.....	63
Product	
Features.....	13
Product recycling (WEEE) .....	11
Product support.....	71

## R

Radio Frequency (RF) interference.....	27
RayNet.....	42
cables .....	77–78
Reset .....	58–59
Reset to factory defaults.....	58–59
Routine checks.....	69

## S

SeaTalkhs LED diagnostics .....	63
SeaTalkng	
Adaptor cables .....	82
Backbone cables .....	82
Connectors .....	82
Kits.....	80
Power cables .....	82
Spur cables.....	81
SeaTalkng cables.....	80
SeaTalkng LED diagnostics.....	63
Service Center.....	71
Servicing.....	69
Set data limit.....	54
Set data warning .....	54
SIM card	
APN.....	54, 66
door .....	29
IMSI.....	53
Inserting.....	29
Management.....	53

SIM info.....	54
Sleep .....	57
Software updates .....	26, 58
Spares .....	76
Status page .....	53
Support forum .....	72
Suppression ferrites .....	27
See <i>also</i> EMC	
System diagram.....	14, 34

## T

Technical specification.....	73
Technical support.....	71–72
Thermal breaker rating.....	37
Tools required .....	25
Training courses.....	72
Transfer ownership.....	11, 23, 59
Troubleshooting .....	62
Power up.....	63
Web interface access .....	65

## U

Upgrading, software .....	58
---------------------------	----

## W

Wake on LAN .....	57
Warranty .....	11, 71
WEEE Directive.....	11
Wi-Fi configuration .....	56
Wi-Fi connection.....	50, 53
Status.....	53
Wi-Fi network	
Connection .....	50
Forget network .....	50

## Y

YachtSense	
------------	--

Off-boat features.....	19
On-boat features.....	17
YachtSense ecosystem.....	17, 36





**Raymarine (UK)**

Marine House, Cartwright Drive,  
Fareham, Hampshire.  
PO15 5RJ.  
United Kingdom.

Tel: (+44) (0)1329 246 700

[www.raymarine.co.uk](http://www.raymarine.co.uk)

**Raymarine (US)**

9 Townsend West,  
Nashua, NH 03063.  
United States of America.

Tel: (+1) 603-324-7900

[www.raymarine.com](http://www.raymarine.com)

**Raymarine Belgium BVBA (EU)**

Luxemburgstraat 2, 2321 Meer.  
Belgium.

Tel: (+32) (0) 3665 5162

[www.raymarine.com](http://www.raymarine.com)



**Raymarine®**